

PRESYS®



Universal Digital Indicator DMY-2030 *Light* 5S Energy

Technical Manual

ATTENTION!

In case of failure, the instrument can provide AC voltage levels in its metal box, which for safety reasons must always be connected to an effective ground point. To this end a suitable terminal is provided on the back of the box identified as GND. Never connect this terminal to the neutral terminal of power supply.

It is recommended the use of an external fuse (2 A) on the power input of the instrument. There is an internal fuse.

Operation of relays - Important Note!

When the instrument has relay module for alarm or control, you must follow the instructions in this manual in the maintenance section on the snubber use.

The snubber is a protection against noise coming from the opening / closing of the relay contacts, but depending on the application may be necessary to remove this snubber!

ATTENTION!

The instrument described in this manual is a device for use in specialized technical area. The user is responsible for configuration and selection of values of the instrument parameters. The manufacturer warns of the risks of occurrences with damage to both the person and the property resulting from the incorrect use of the instrument. The information and specifications in this manual are subject to change without previous notice.

Table of Contents

| | |
|---|-----------|
| 1.0 - Introduction | 1 |
| 1.1 - Description | 1 |
| 1.2 - Order Code | 2 |
| 1.3 - Technical Specifications..... | 4 |
| 2.0 - Installation | 6 |
| 2.1 - Mechanical Installation | 6 |
| 2.2 - Electrical Installation | 7 |
| 2.3 - Process Input Signal Connections | 7 |
| 2.3.1 - Thermocouple Connections..... | 8 |
| 2.3.2 - RTD Connections | 8 |
| 2.3.3 - Current Input | 9 |
| 2.3.4 - Voltage inputs..... | 10 |
| 2.4 - Output Connections | 10 |
| 2.5 - Connection Diagram | 12 |
| 2.6 - Engineering Units..... | 13 |
| 3.0 - Operation | 14 |
| 3.1 - Normal Operation..... | 14 |
| 3.2 - Configuration..... | 16 |
| 4.0 - Maintenance..... | 29 |
| 4.1 - Hardware | 29 |
| 4.2 - Using snubber with relays | 30 |
| 4.3 - Optional Modules Installation | 31 |
| 4.4 - Calibration..... | 34 |
| 4.5 - Hardware Maintenance Instructions | 39 |

PRESTY

1.0 - Introduction

1.1 - Description

The DMY-2030-Light-5S-Energy is ideal for security applications in turbines, hydroelectric plants and thermoelectric generators. It has monitoring capability of one universal standard input, accepting direct connection of RTD, thermocouple, current (mA_{dc}) and voltage (mV_{dc}, V_{dc}). The inputs RTD and thermocouple are automatically linearized by tables stored in the EPROM. A 24 V_{dc} power supply, isolated from the output and short circuit protection is provided for transmitters.

The type of input selected by the user is enabled through via software configuration, following the input signal connection to the appropriate terminals. All configuration data are protected by a system password and are stored in non-volatile memory in case of power failure.

Designed within the concept of modularity, accepts up to 5 output cards. Can have a retransmitter output (4-20 mA, 1-5 V, 0-10 V) and up to four relay outputs (SPST relay, SPDT relay, solid state relay or open collector voltage). In case of sensor breaking, the trip alarm is not triggered (configurable for 4-20 mA, 1-5 V, TC and RTD inputs) and the analog output takes preconfigured security value. The alarm outputs can be configured, independently, to work with latch, demanding recognition of the operator through the front-panel push-buttons of the instrument to be disabled after the return of the process variable to normal. The outputs are electrically isolated from the inputs. In addition to the high and low alarms, you can set the indicator for failure alarms (*watchdog*).

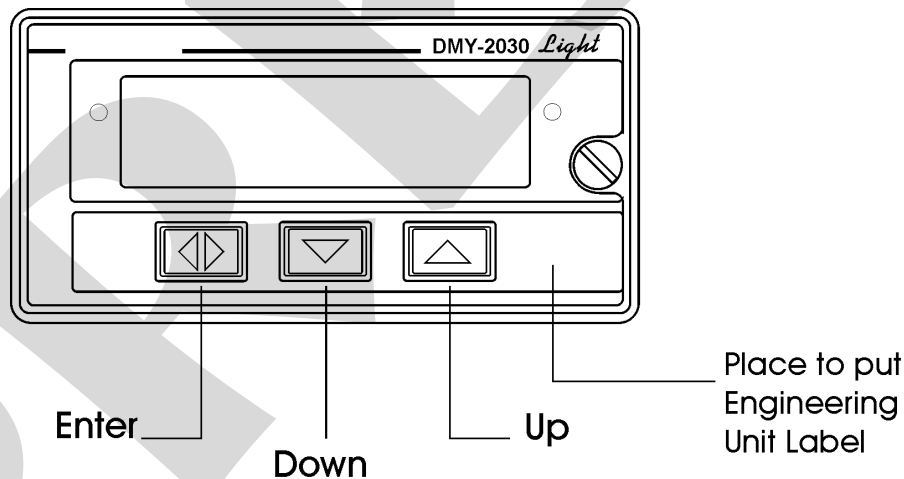

Fig. 1 - DMY-2030-Light-5S-Energy Front Panel

The front panel has a high visibility display configurable up to 4 ½ digit to show the process variable. The pair of leds is used as a visual indication of the execution of the start-up process, in which the state of the alarm relays is kept fixed for a period of time defined by the user. In setup time, the display shows the mnemonic and parameter values.

Allows a universal power 75-264 Vac50/60 Hz or 100-360 V_{dc} (any polarity).

| | |
|---------|--|
| Field G | Case Protection Grade |
| 0 | General usage, protected place |
| 1 | Front aspersion-proof |
| 2 | Weather-proof |
| 3 | Explosion-proof (BR-Ex d IIB T6 IP 65), horizontal display (*) |
| | (*) Explosion-proof box: Dimensions: 310x310x200mm (HxWxD) Weight: 11 kg approx. |
| Field H | Application |
| E | Energy |

Notes 1 - The input type, the indication, the retransmitter output and the use of alarm relays are items that the user can program through the front keys (if desired, specify this information so that all programming is done by Presys).

Note: Any other desired feature, software or hardware may be available upon request.

Code Example:

1) DMY-2030-Light-5S - 4 - 4 - 0 - 1 - 1 - X - 0 - E

This code defines an indicator DMY-2030-Light-5S-Energy with two SPST relays, one SPDT relay for use as alarm with configurable trip function, one analog output, power supply for the range 75-264 Vac 50/60Hz or 100 to 360 Vdc, for use in protected place.

1.3 - Technical Specifications

Input:

- RTD Pt-100 under DIN 43760, thermocouple (J, K, T, E, R, S, under ITS-90), 4-20 mA, 0-500 mVdc, 1-5 Vdc, 0-10 Vdc. Input impedance of 250 Ω for mA, 10 MΩ for 5 Vdc and 2 MΩ above 5 Vdc. The table below shows the temperature ranges for thermocouples and RTD, and the resolution for linear input sensors.

| Input Sensor | Range | | | |
|-----------------------------|-------------------|--------------------|-------------------|--------------------|
| | lower limit °F | higher limit °F | lower limit °C | higher limit °C |
| <u>Thermocouple</u> | | | | |
| Type J | -184.0 | 1886.0 | -120.0 | 1030.0 |
| Type K | -346 | 2498 | -210 | 1370 |
| Type T | -418 | 752 | -250 | 400 |
| Type E | -148.0 | 1436.0 | -100.0 | 780.0 |
| Type R | -58 | 3200 | -50 | 1760 |
| Type S | -58 | 3200 | -50 | 1760 |
| <u>RTD</u> 3-wire Pt-100 | -346.0 | 752.0* | -210.0 | 400.0* |
| <u>Linear</u> | Range | | Resolution | |
| Voltage | 0 to 500 mV | | 25 μV | |
| | 1 to 5 V | | 250 μV | |
| | 0 to 10 V | | 500 μV | |
| Current | 4 a 20 mA | | 1 μA | |

(*) including wire resistance

Outputs:

Up to 5 modules:
 - 01 x Analog (4-20 mA; 1-5 Vdc; 0-10 Vdc) + up to 04 relays (2 x SPST + 2 x SPDT), 3 A/220 Vac. Logic signal, open collector transistor 24 Vdc/40 mA maximum with isolation. Solid state relay, 2A/250 Vac with isolation.

Indication:

Standard indication of -9999 to 19999 range.

Configuration:

By front-panel push-buttons and internal jumpers (for analog output).

Sampling Rate:

64 ms sampling rate, for the indication of input in -9999 to 19999 range. The display is updated each 0.5 second.

Accuracy:

- ± 0.1 % of full scale for TC, RTD, mA, mV and V input.
- ± 0.5 % of full scale for analog retransmitter output and 750Ω maximum load.

Linearization:

± 0.1 °C for RTD and ± 0.2 °C for TC.

Square root extraction:

± 0.5 % of reading, for input above 10% of span. 0 to 5% programmable Cut-off.

Cold junction compensation:

± 2.0 °C at range from -10 to 60°C ambient temperature.

Thermal stability:

± 0.005 % / °C of span with reference of 25°C ambient temperature.

Power Supply:

Universal 75 to 264 Vac 50/60 Hz or 100 to 360 Vdc (any polarity), 10 W nominal; 24 Vac/dc (± 10 %), 12 Vdc (± 10 %) and other values are optional.

2-wire transmitter power supply:

24 Vdc voltage and 50 mA maximum, isolated from output, short-circuit protection.

Operating Ambient:

-10 to 60 °C temperature and 90% maximum relative humidity.

Dimensions:

1/8 DIN (48 mm x 96 mm x 185 mm), HxWxD,
panel cutout 45 mm x 92 mm, HxW.

Weight:

0.5 kg nominal.

Warranty:

One year.

2.0 - Installation

2.1 - Mechanical Installation

DMY-2030-Light-5S-Energy Indicator front panel has 1/8 DIN size (48 x 96mm). It is fixed by the rails which press it against the back side of the panel.

After preparing a 45 x 92 mm cut in the panel, remove the rails from the Indicator and slide its rear through the cut until its front reaches the panel. Place the rails again in the Indicator from the back of the panel and tighten the screws as shown in figure 2.

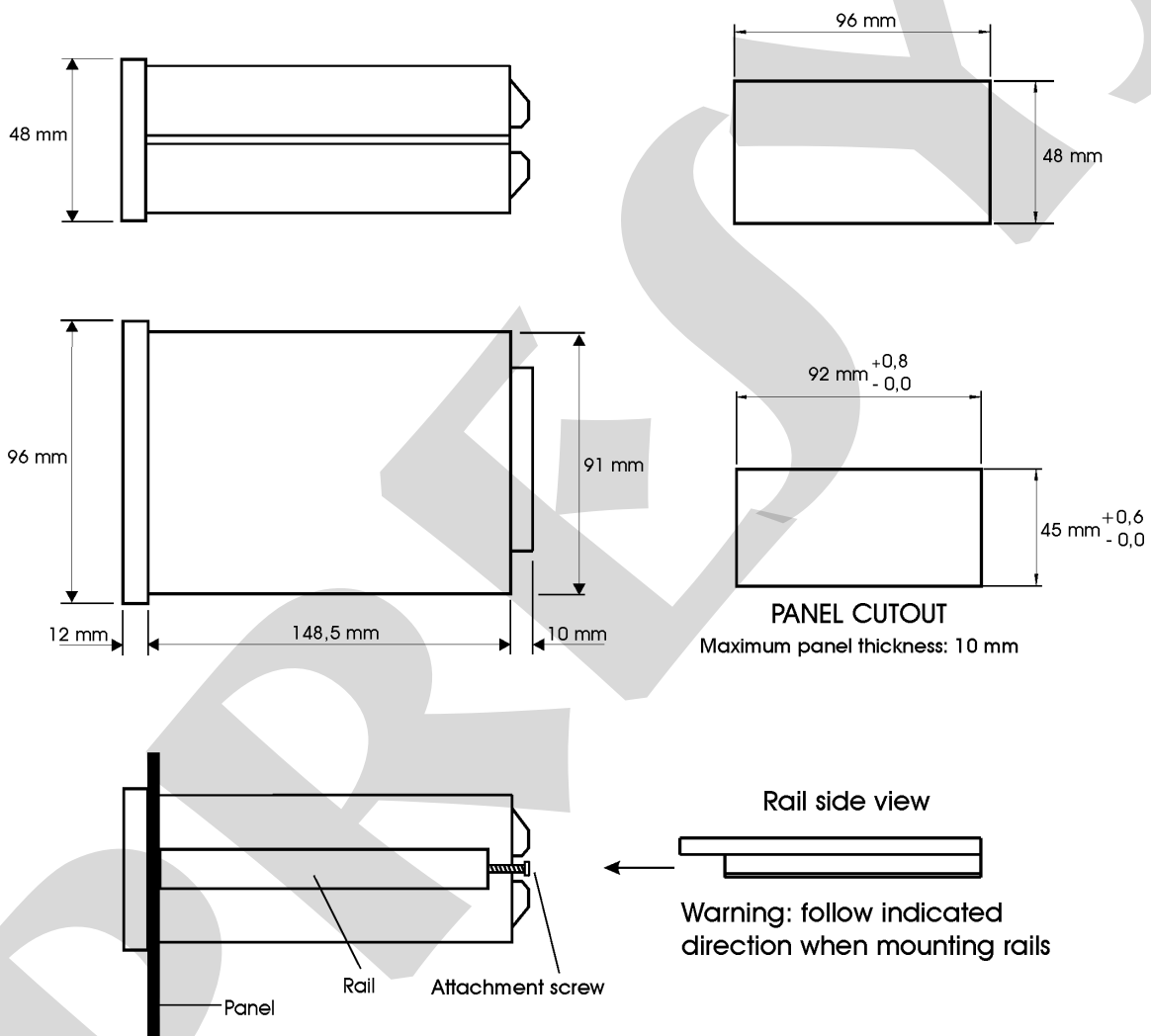

Fig. 2 - Dimensional drawing, panel cutout and side view

2.2 - Electrical Installation

DMY-2030-Light-5S-Energy Indicator may be powered by voltage between 75 and 264 Vac or 100 to 360 Vdc, any polarity. Remember that the internal circuit is powered whenever the instrument is connected to the external power supply.

Input and output connections must be connected to the instrument only when it is turned off.

Figure 3 shows the instrument rear terminals for connection of power supply, ground, communication, process input and output signals.

Signal wiring must be kept far away from power wires.

Due to its metal case the instrument ground should be connected to earth ground. Never connect the ground to neutral terminal.

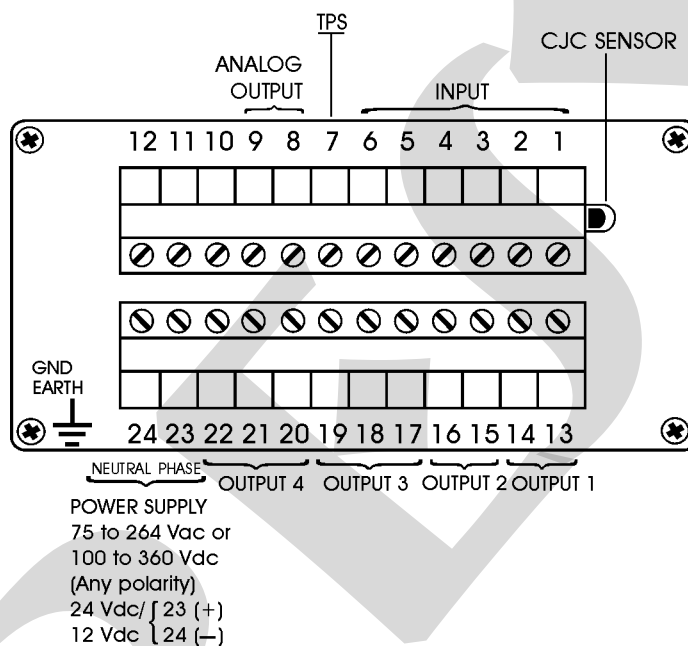

Fig. 3 - Indicator Terminals

2.3 - Process Input Signal Connections

The Indicator universal standard inputs can be connected to thermocouples, 3-wire RTD, current (mA) or voltage (V or mV). See the different types and ranges of input sensors in table 1, section 1.3 on Technical Specifications.

The input sensor is enabled by software configuration (see section 3.2 on Configuration) and by the selection of the appropriated terminals of the instrument.

In order to avoid noise in the wiring, use twisted pair cable and cross sensor connection wire inside a metallic tube or use shielded cable. Make sure to connect only one shield wire end either to terminal or to sensor ground, as shown in the next items.

WARNING: GROUNDING TWO SHIELD WIRE ENDS MAY CAUSE NOISE IN THE INDICATOR.

2.3.1 - Thermocouple Connections

Connect the thermocouple to terminals 2(+) and 3(-) as shown in figure 4.

In order to reduce the error due to cold junction compensation, use thermal paste in the rear (from the terminals where the thermocouple is connected to the cold junction sensor). Use appropriate compensating cables with the same material of the thermocouple in order to connect it to the instrument. Check if the thermocouple polarity is equal to those of the terminals.

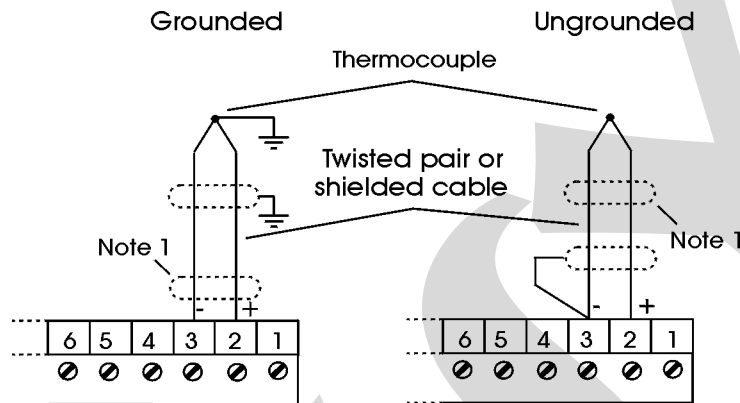

Note 1: Keep the shielded cable disconnected at this end.

Fig. 4 - Thermocouple Connections

2.3.2 - RTD Connections

The 3-wire RTD is connected to terminals 1 and 3, and the compensation wire is connected to terminal 2.

Use wires of same material, gauge and length on all 3 for compensating resistance. The maximum resistance of each connection wire must be 10 Ω. Use 18 AWG wire (minimum) for distances up to 50m and 16AWG for distances greater than 50 m.

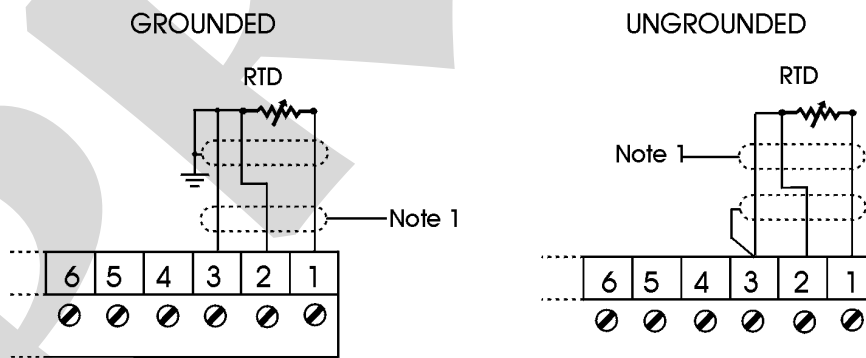

Note 1: Keep the shielded cable disconnected at this end.

Fig. 5 - RTD Connections

2.3.3 - Current Input

The 4-20 mA current signal is applied to terminals 5(+) and 6(-). The current signal can be generated by a transmitter with an external power supply. In case of using the 24 Vdc internal voltage source from the Indicator to power a two-wire transmitter, the current is received only by terminal 5(+). Figure 6 shows both possibilities of connection.

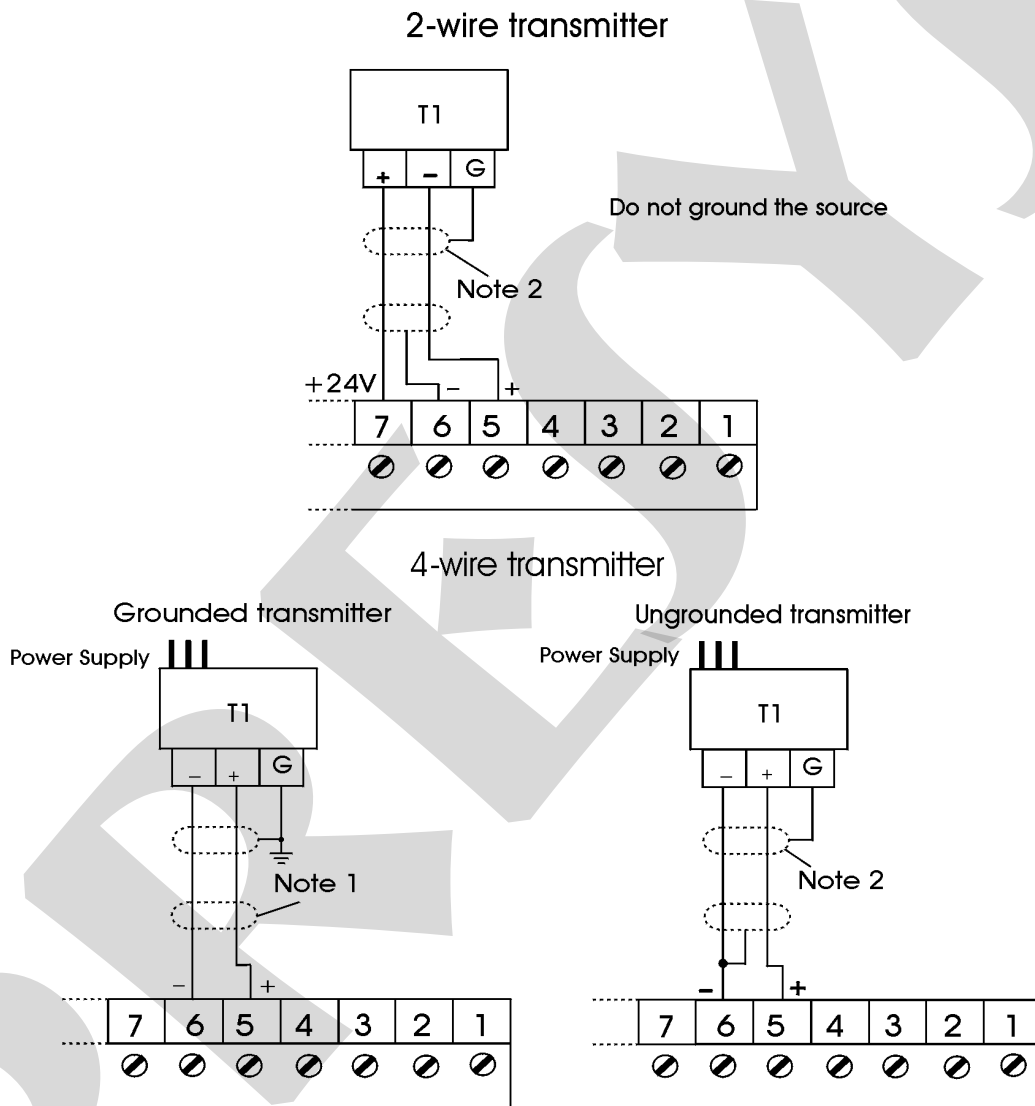

Note 1: Keep the shielded cable disconnected at this end.
 Note 2: Connect the shielded cable to transmitter ground terminal.
 When there is no ground terminal, keep the shielded cable disconnected at this end.

Fig. 6 - Current input connections

2.3.4 - Voltage inputs

0 to 55mVdc or 0 to 5 Vdc must be applied to terminals 2 (+) and 3 (-). 0 to 10Vdc must be applied to terminals 4(+) and 6(-). The connections are shown in figure 7.

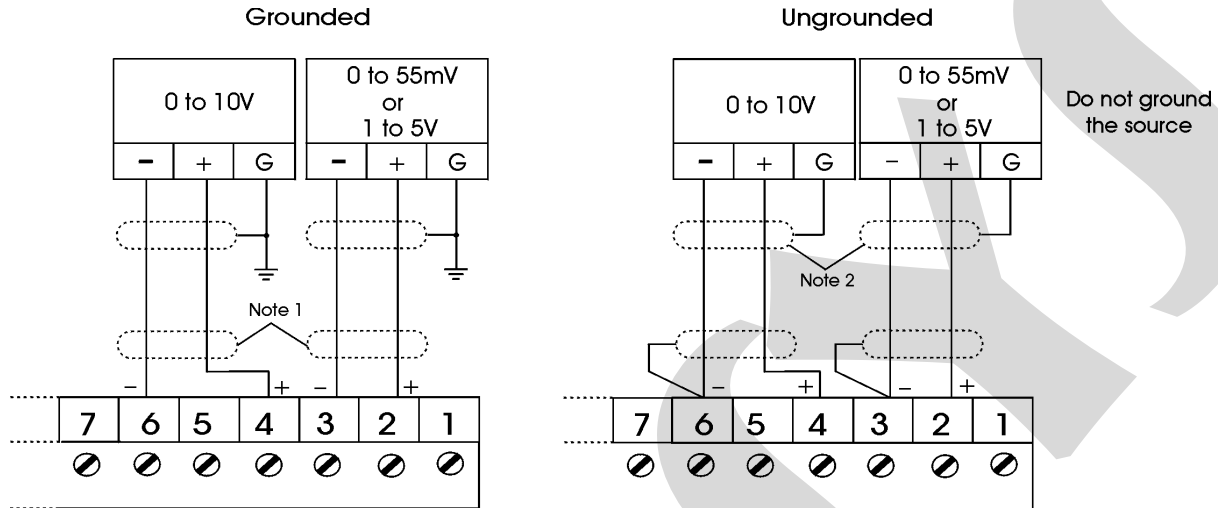

Note 1: Keep the shielded cable disconnected at this end.

Note 2: Connect the shielded cable to ground terminal. When there is no ground terminal, keep the shielded cable disconnected at this end.

Fig. 7 - Voltage source connection

2.4 - Output Connections

The Indicator can have up to five output modules: output 1 to 4 are only used as alarm outputs and the output other one as retransmitter output (4-20 mA, 1-5 Vdc or 0-10 Vdc). Figure 8 shows the Indicator output types.

Note that the output terminals will present the corresponding signals only if the optional modules are installed and the output is correctly configured. Refer to section 3.2 on Configuration and 4.3 Optional Modules Installation for further details.

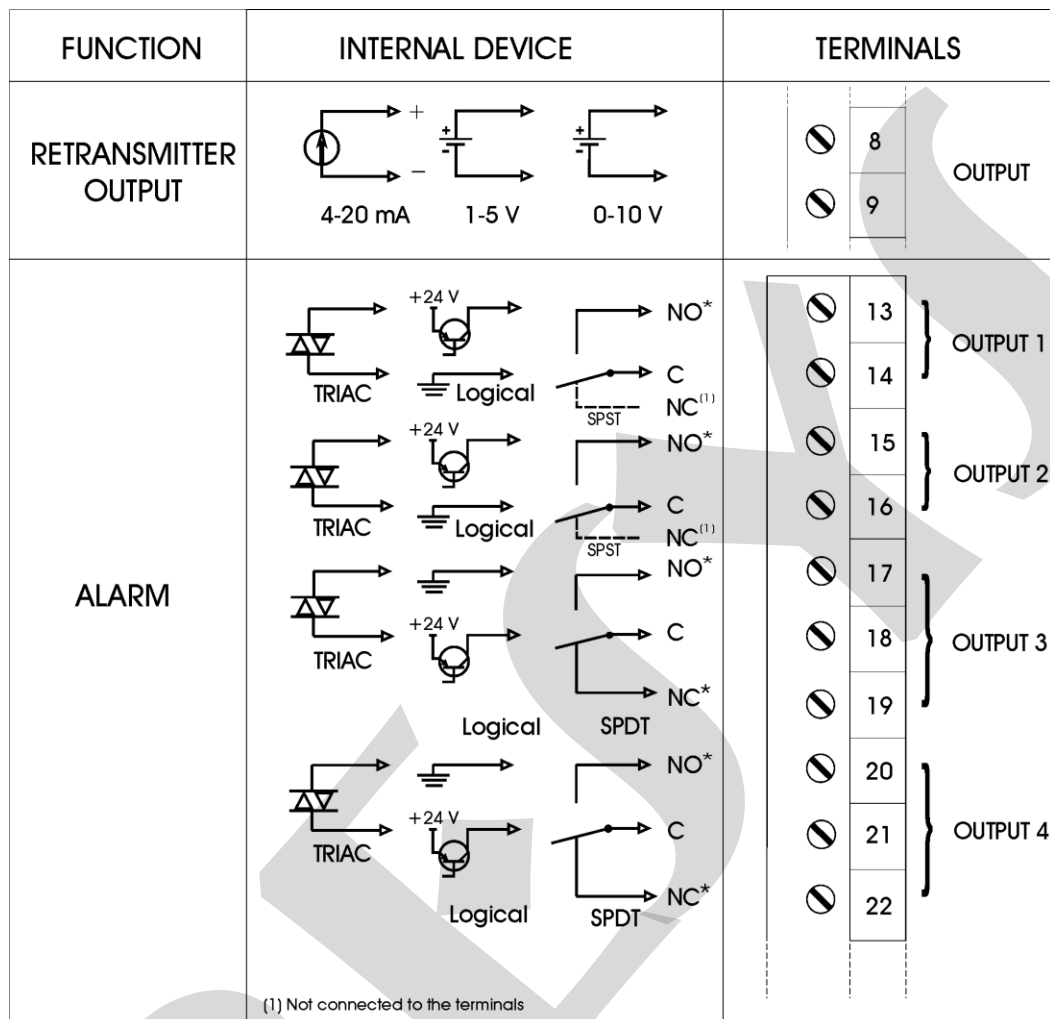

(*) The relay contacts assume that the instrument is off.

Fig. 8 - Output Connections

The state of the relay contacts illustrated in Figure 8 assume the instrument turned off. If the power is on, the status (open or closed) depends on the SAFE setup and if the instrument is in alarm condition or not. Table 2 shows the state of the relay contacts in all conditions.

| Power | SAFE | Alarm Condition | Relay 1 Terminals 13 and 14 | Relay 2 Terminals 15 and 16 | Relay 3 Terminals 17 and 18 | Relay 4 Terminals 20 and 21 |
|-------|------|-----------------|-----------------------------|-----------------------------|-----------------------------|-----------------------------|
| Off | --- | --- | Open | Open | Open | Open |
| On | Yes | No | Closed | Closed | Closed | Closed |
| On | Yes | Yes | Open | Open | Open | Open |
| On | No | No | Open | Open | Open | Open |
| On | No | Yes | Closed | Closed | Closed | Closed |

The factory setting for the relays is SAFE = NO for trip relays and SAFE = YES for the others.

2.5 - Connection Diagram

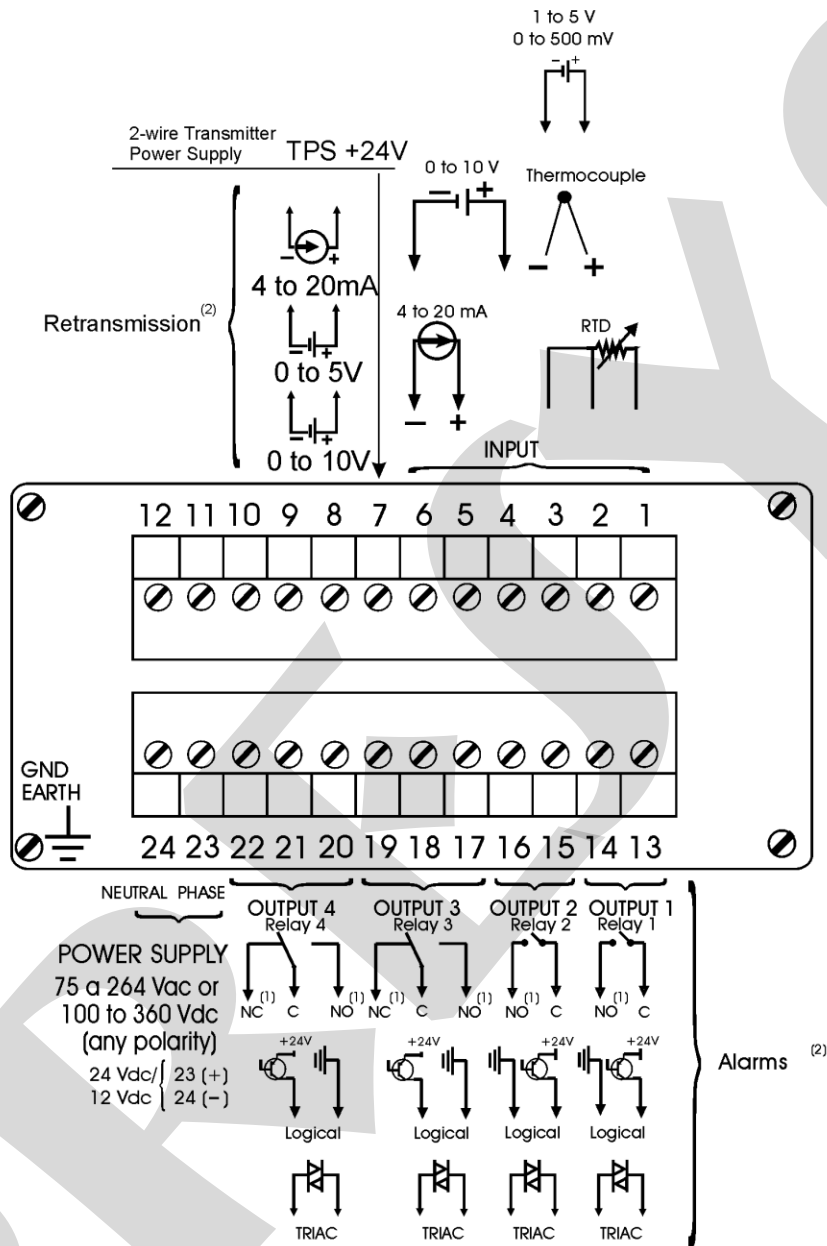

Notes:

(1) The relay contacts (NF and NA) assume that the instrument is off. When you switch it on, the state of the relays depends on the SAFE configuration and whether the instrument is or not in alarm. The table below shows the state of the relays in all possible conditions.

| Power Supply | SAFE | Alarm Condition | Relay 1 Terminals 13 and 14 | Relay 2 Terminals 15 and 16 | Relay 3 Terminals 17 and 18 | Relay 4 Terminals 20 and 21 |
|--------------|------|-----------------|-----------------------------------|-----------------------------------|-----------------------------------|-----------------------------------|
| OFF | --- | --- | Open | Open | Open | Open |
| ON | Yes | No | Closed | Closed | Closed | Closed |
| ON | Yes | Yes | Open | Open | Open | Open |
| ON | No | No | Open | Open | Open | Open |
| ON | No | Yes | Closed | Closed | Closed | Closed |

(2) Optional Modules

Fig. 9 - Connections Diagram

2.6 - Engineering Units

A label with several Engineering Units is supplied with each Indicator. Select the one corresponding to the variable shown on the display and stick it to the front panel of the Indicator.



3.0 - Operation



3.1 - Normal Operation

DMY-2030-Light-5S-Energy Indicator has two modes of operation: normal operation and configuration mode.

During normal operation, the Indicator monitors the inputs, verifies alarm conditions and activates the outputs when necessary.

The configuration mode is used to select and configure all the Indicator parameters.

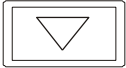
The normal operation mode, in which the Indicator is to be found most of the time, is called level zero. In this level, the three front panel keys have the following functions:

| Key | | Function |
|-------|---|---|
| UP |  | i) If the process variable is being indicated, present the corresponding mnemonics to relays with latch (AC.RL.1 to AC.RL.4) requiring acknowledgment to return to the normal state. ii) When presented the mnemonic CONF, changes from level zero to 1 (Configuration Mode) or asks for a password depending on configuration. iii) Increase the alarm set point value shown if the edition of set points alarm is enabled. |
| DOWN |  | i) Decreases the value of the displayed alarm set point if the the alarm set point edition is enabled. ii) If the process variable is being indicated, presents the mnemonic ST.UP to the beginning of the start-up or AB.S.U. to abort a start-up that was already started. |
| ENTER |  | i) Changes the information shown in on the display. If the display is showing the process variable, will show the alarm set point 1, if configured. Then you can go to the alarm set points 2-4, the CONF menu (access to the configuration levels) and again to the process variable. If the visualization of alarm setpoints is disabled, the display alternates between the display and CONF. ii) Effectives relay acknowledgment (AC.RL.1 to AC.RL.4) with latch after the alarm condition, when the mnemonic is accessed by the UP key while the process variable is displayed: iv) When presented the mnemonic ST.UP initiates the start-up; and the mnemonic AB.S.U., the start-up is aborted. |

The information sequence presented on the display is shown in figure 10.

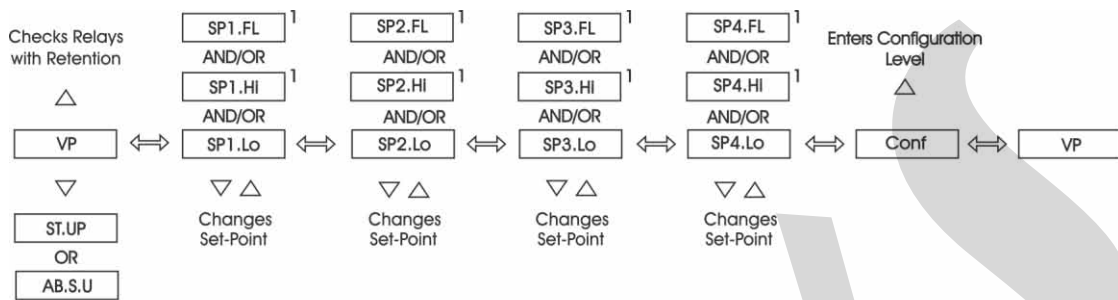

(1) The viewing and editing can be blocked in configuration mode. For more details, see section 3.2 Configuration - General Level.

Fig. 10 - Information in the operation level.

The normal operation and configuration modes present a “timer” which makes the display return to the process variable, when it shows any other information and no key is pressed for 1 minute. It does not apply to the Calibration level (Calib. mnemonic). See item 3.2 on Configuration.

In operating mode, the relay configured to trip alarms with Fail manual reset (See section 3.2 - Configuration: Levels 5 and 6 – ALAR.3 and ALAR.4) are reactivated by the following procedure:

- (i) The message B.OUT (for RTD or TC input) or BREAK (for 4-20 mA current or 1-5 V voltage inputs) flashes on the display, indicating that the sensor is broken and the trip alarm is disabled;
- (ii) Redo the connection of the terminal block;
- (iii) The display starts to alternately display the words of the process variable and the mnemonic FAIL (relays 3 and/or 4 disabled);
- (iv) Activate relays with trip alarm as follows:
 1. Go to CONF and press UP to display the PASSWORD display;
 2. Press UP, DOWN and ENTER;
 3. FAIL disappears from the display and the display returns to show the process variable with the trip alarms already reactivated.

3.2 - Configuration

In order to access the configuration mode the operator is required to provide a password which avoids a non-authorized person to change any critical parameters of the process.

Thus, when press the ENTER key while the process variable is displayed within the normal operating mode, the following cases may occur, depending on the configuration:

- i) Go straight at level 1 (GENERAL) of configuration mode, indicating that the instrument has not been configured with a password system;
- ii) On indicator display will show the warning PASS, indicating that the instrument has a password system that can be a key or value, as shown in Figure 11.

Note: In the diagrams below, the rectangles represent the display appearance after pressing the keys.

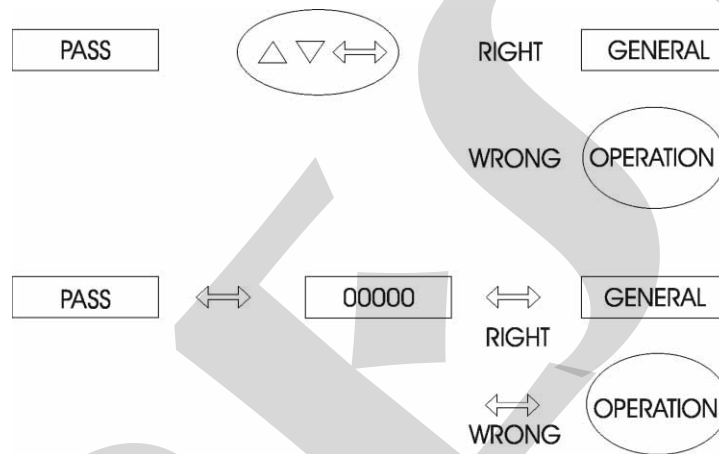

Fig. 11 - Password system

In the case of password key, the user must sequentially pressing the UP, DOWN and ENTER key to enter the setting levels.

In the case of password with value the user must press for the second time the ENTER key to display the number 00000 with the last zero flashing. The flashing digit indicates the position where the user will enter a five-digit number password. To move to the other digits of the left press the ENTER key. After entering all digits, press ENTER again to move to level 1 if the password is correct, otherwise back to normal operation (See Figure 11).

You can even select both password system, key and value. In this case, upon receiving the password prompt the user to enter a sequence of incorrect keys he falls immediately in the password system value.

When there are relays with trip alarms, the password system by keys will be booked to reactivate the relays after a sensor break, while the password value is permanently enabled to give access to the configuration levels.

The password can be a user-chosen number (custom) or the number 2030. Note that for a password value the number 2030 is always enabled to help in case the user forgets the password.

To enter a number for the password or any other parameter value is used indicator of the front buttons with the following functions:

| Key | Function |
|-------|----------------------------------|
| UP | Increments the digit |
| DOWN | Decrements the digit |
| ENTER | Changes to the digit on the left |

All configuration parameters are stored in the non-volatile memory and determine the normal operation of the instrument. With these parameters the user can adjust the instrument to his needs, when it is necessary to change the configuration from factory.

Configuration parameters are distributed in eight hierarchical levels shown in figure 12.

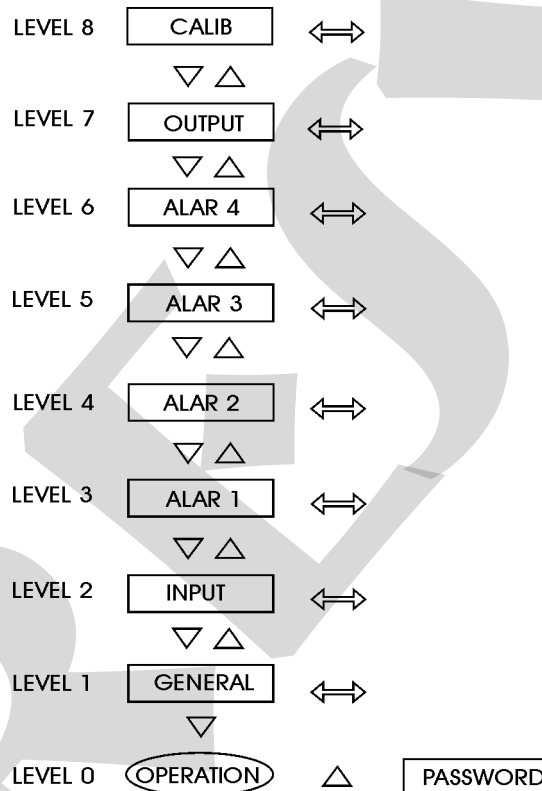

Fig. 12 - Parameter levels diagram

In order to move through the levels and access the parameters of any one of them, use the front panel keys which have the following functions:

| Key | Function |
|-------|------------------------|
| UP | Moves to higher levels |
| DOWN | Moves to lower levels |
| ENTER | Enters the level |

The Indicator allows the user to know what kind of input, alarms or output are configured without the need to access a specific parameter level. The mnemonics corresponding to the level and to the configuration chosen move on the display continuously, as soon as one reaches one of the levels (except Calib. and General).

Inside each level, the front panel keys have the following functions:

| Key | Function |
|-------|---|
| UP | Moves the options in increasing direction |
| DOWN | Moves the options in decreasing direction |
| ENTER | Confirm or go forward in options inside a level, if the display does not show ESC. When ESC is shown, it returns one or more positions. |

When accessing any parameter of a configuration level, the Indicator directly shows the option or value corresponding to the current configuration of the parameter. In case a value is presented, use the UP and DOWN keys to change each digit and press ENTER to move to the next one. When configuring the options of a parameter, the UP and DOWN keys are used to move through the options and the ENTER key, to confirm the choice.

The hierarchical levels are presented in sequence. The options of each level are explained step by step with all their corresponding parameters.

Level 1 - General

Level 1 presents the options: PASS, TRIP, ALAR and ST.UP (see figure 13).

PASS - allows the user to enable or disable the password system for accessing the configuration mode. The password system may be chosen as a key sequence, a value (number chosen by the user and number 2030) or both. The correct key sequence is obtained by pressing the UP, DOWN and ENTER keys in this order. When there are trip alarm relays, the value-type password system is enabled, while the password key sequence is now reserved to reactivate the alarm relays.

TRIP - enables alarms 3 (ALAR.3) and 4 (ALAR.4) as trip alarms (for 4-20 mA current, 1-5 V voltage or temperature inputs), preventing the alarm to be activated in case of sensor breaks or at the moment the sensor is reconnected. The alarms can be configured as high-trip (HI) or low (LO). To disable the trip function, set TRIP as NO, so that the relay 3 or 4 works in the same way relays 1 and 2 do.

ALAR - allows you to select one of three display modes for the alarm setpoints in the operation mode: Hide, Lock and All. The Hide option hides the alarm setpoints. The Lock option allows the user to view the setpoint, but not to modify it. Finally, the All option allows the setpoints to be both viewed and changed.

ST.UP - configures the start-up operation by selecting the relays to be used (RELAY), their state (ST.RL), execution time (Time) and indication (INDIC).

In RELAY the user can select the relays to remain fixed during the start-up according to their type: relays with normal configuration or without trip (NORM), relays with trip (TRIP), all relays (ALL) or none (NONE).

In ST.RL these relays can be configured to maintain their contacts in the last state found when the start-up begins (LAST option) or to be released to return to the non-alarm state (RLS option).

The start-up execution time (TIME) is set between 0 and 250 s.

To launch the start-up press the DOWN key during the indication of the process variable and select the ST.UP mnemonic. In order to turn the start-up operation off before the execution time is completed or in case it was set to zero, the operator can select the AB.S.U. mnemonic, available after the DOWN key is pressed.

In INDIC configure the execution of the start-up to be indicated by the ST.UP mnemonic alternating with the process variable (DISP option) or by a blinking LED on the front panel (LED1 and LED2 options).

The table below refers to the ranges of the parameters shown in Figure 13.

| Mnemonic | Parameter | Range | Factory Value | Units |
|----------|-------------------------|----------------|---------------|---------|
| VALUE | user password | -9999 to 30000 | 0 | _____ |
| TIME | start-up execution time | 0 to 250 | 0 | seconds |

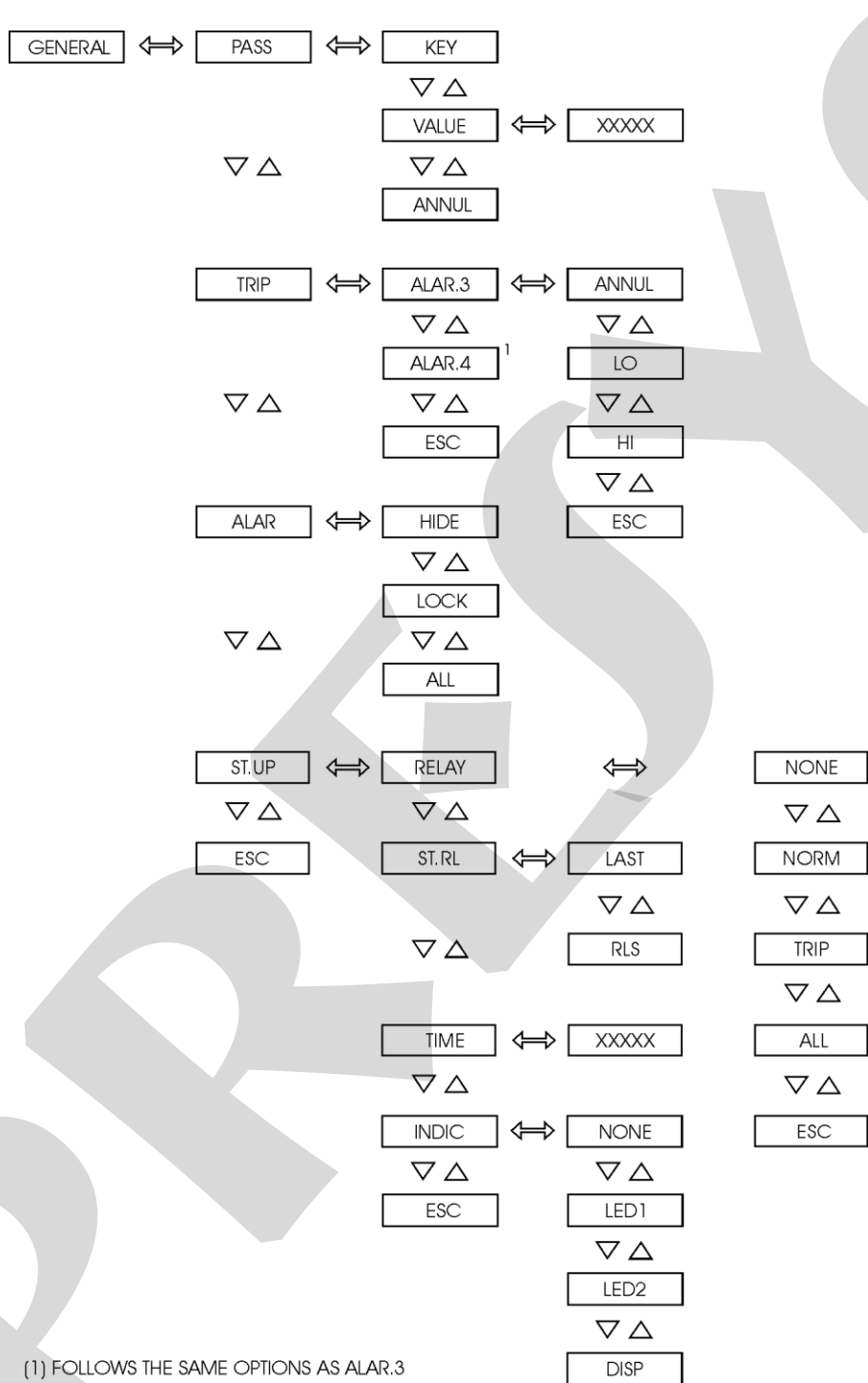

Fig. 13 - General Level Options

Level 2 - Input

The input sensors, described in table 1 of section 1.3 on Technical Specifications, are configured according to the parameters of the Input level shown below:

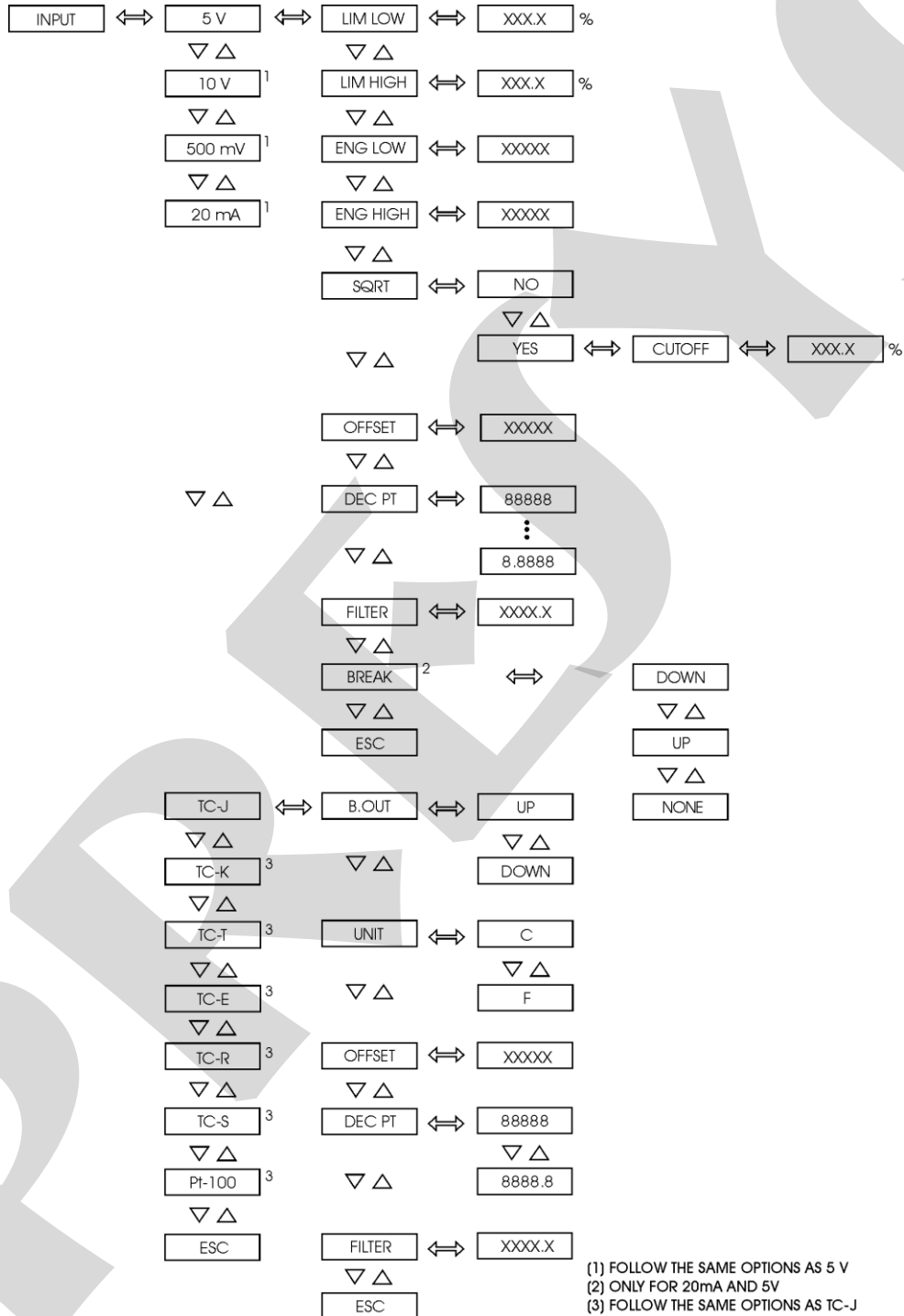

Fig. 14 - Input Level Options

The table below refers to the ranges of the linear sensor input parameters shown in figure 14.

| Mnemonic | Parameter | Range | Factory Value | Units |
|----------|---|----------------|---------------|---------|
| LIM LOW | input signal associated to Eng Low | 0.0 to 100.0 | 0.0 | % |
| LIM HIGH | input signal associated to Eng High | 0.0 to 100.0 | 100.0 | % |
| ENG LOW | display indication associated to Lim Low | -1009 to 20019 | 0.0 | EU* |
| ENG HIGH | display indication associated to Lim High | -1009 to 20019 | 100.0 | EU |
| CUT-OFF | minimum value for the square root extraction | 0 to 5 | 0 | % |
| OFFSET | constant added to the display indication | -9999 to 30000 | 0 | EU |
| FILTER | time constant of a first order digital filter | 0.0 to 25.0 | 0.0 | seconds |

(*) EU - Engineering unit

When selecting a linear sensor one must configure its scale. Define two points P1 (Lim Low, Eng Low) and P2 (Lim High, Eng High), as shown in figure 15. Lim Low represents in % the value of the electrical signal associated to the display indication - Eng Low - and Lim High represents in % the value of the electrical signal associated to the display indication - Eng High.

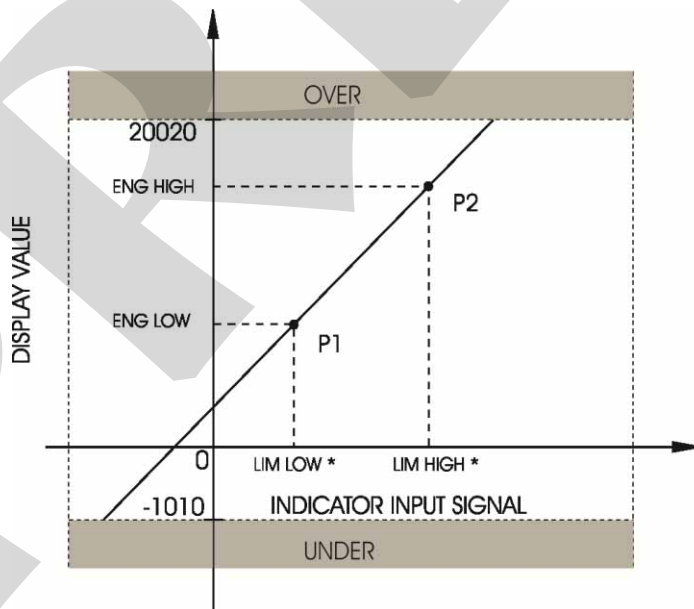

Fig. 15 - Linear Input Configuration

SQRT - allows presenting on the display the squared root of the linear input signal. The Cut-Off parameter given in % of the full scale makes input values below Cut-Off to be shown as zero scale. See figure 16.

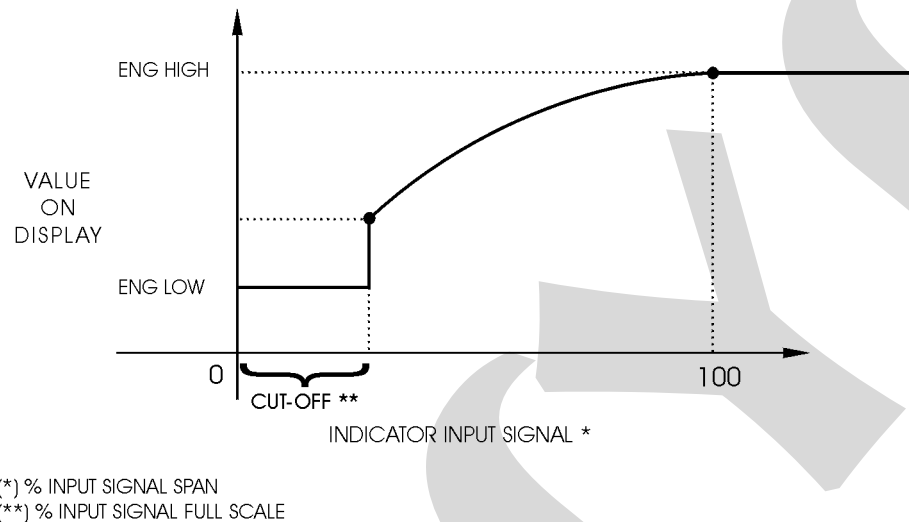

Fig. 16 - Input signal square root

DEC.PT - sets the decimal point position for visualization of engineering units in display. There are up to four decimal for linear signals, and for temperature sensors there is one decimal or none.

OFFSET - allows the user to enter an off-set value in engineering units to be added to the measured variable.

FILTER - this parameter gives the time constant of a first order digital filter coupled to the input. When you do not want the filtering of the measured signal, just set zero to this parameter.

BREAK - determines the direction of change of the indication when a sensor break is detected for the 4-20 mA current or 1-5 V voltage inputs. This option can be configured as DOWN (downscale), UP (upscale), or NONE (no change). Its choice is made so that the alarms associated with relays 1 and 2 are not activated.

B.OUT - When temperature sensors break (thermocouple or RTD) or there are disconnected wires, the display indicates burn-out. In this case, choosing the UP option for this parameter activates the high-alarms and the DOWN option activates the low-alarms.

UNITS - selects °C or °F for temperature indication.

Levels 3 to 6 - Alarms

The indicator can have up to four physical devices for alarms: relays 1, 2, 3 and 4.

ALAR1, ALAR2, ALAR3 and ALAR4 mnemonics correspond to the configuration levels for alarms 1 to 4, respectively. The connectors on the Power Supply Board for the installation of each one of the relays are listed below:

| Relay | Board Connectors |
|-------|------------------|
| 1 | MOD1 (Output 1) |
| 2 | MOD2 (Output 2) |
| 3 | MOD3 (Output 3) |
| 4 | MOD4 (Output 4) |

Refer to section 4.3 on Optional Modules Installation for the installation details.

Each device can be configured as high (HI mnemonic), low (LO) or fail (FAIL) alarm. The Fail alarm is activated when there is a sensor break, for inputs configured as temperature (RTD or TC), 4-20 mA current or 1-5 V voltage. When configuring an alarm as high or low is necessary to set its set point (SP) and hysteresis (HYST). There is no configuration of these parameters for fail alarms.

Relays 3 and 4 may be configured as trip alarms for the temperature (RTD or TC), 4-20 mA current or 1-5 V voltage inputs, preventing the alarm to be activated in case the sensor breaks or at the moment the sensor is reconnected. Trip alarms are enabled in the GENERAL level by means of the TRIP mnemonic. To enable the trip function for relay 3 or 4 (ALAR3 and ALAR4 options), select HI (high trip) or LO (low trip). To disable the trip function, select ANNUL, so that the relay 3 or 4 works in the same way as relays 1 and 2 do.

Once the trip type is selected, one must configure the parameters of the same type of alarm (HI or LO) in the ALAR3 or ALAR4 level. Thus, if a high trip is selected, for example, one must configure the high alarm (HI) and its parameters (SP and HYST).

When there is sensor break, the alarm of a trip relay ceases to be checked temporarily (*relay disabled*), although it remains configured in the ALAR3 or ALAR4 level. Right after the relay is disabled the state of the alarm is determined by the RL.F option (shown after the selection of the alarm type). When configuring RL.F as RLS (release), the relay is released from the alarm state of the input with the broken sensor (maintaining the contact in the non-alarm position). When LAST is selected for RL.F, the relay maintains the last alarm state presented by the input with the broken sensor. In this way, for relay 3 with a high trip alarm and in alarm condition, for instance, the sensor break would change the relay contact to the non-alarm position for RLS, while its position would be maintained for LAST.

After the proper reconnection of the sensor to the input, one must apply a reset to the disabled relay so that the instrument continues to check the alarm which was disabled. The reset mode is defined by the RST.F option as automatic (AUTO) or manual (MANU). RST.F is shown together with RL.F mnemonic after the selection of the alarm type. For the automatic reset mode, the alarm relay is re-enabled as soon as the instrument detects the sensor connection, while the manual reset mode requires the operator to apply the reset in the operation level of the instrument. For the latter case,

the end of the break condition makes the display to alternate between the process variable indication and the RL.OUT mnemonic. In order to apply the reset, first go to the CONF mnemonic and press ENTER to display the PASS mnemonic. Then press the UP, DOWN and ENTER keys to enable the alarm. The display returns to the exhibition of the process variable.

Note that the trip function does not apply to the 10 V and 500 mV inputs. It is only possible to configure the fail alarm for relays 3 and 4 with the trip function disabled.

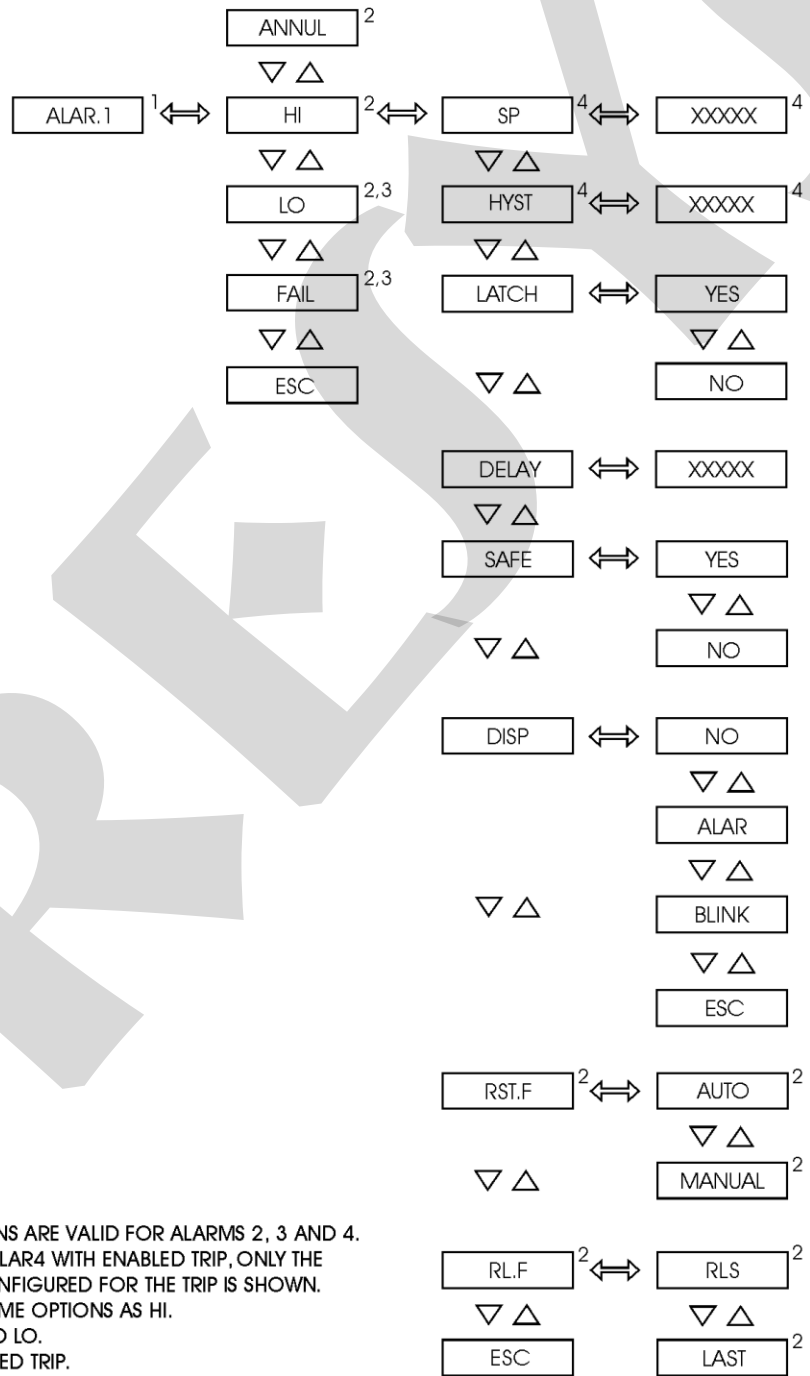

- (1) THE SAME OPTIONS ARE VALID FOR ALARMS 2, 3 AND 4.
- (2) FOR ALAR3 OR ALAR4 WITH ENABLED TRIP, ONLY THE ALARM TYPE CONFIGURED FOR THE TRIP IS SHOWN.
- (3) FOLLOWS THE SAME OPTIONS AS HI.
- (4) ONLY FOR HI AND LO.
- (5) ONLY FOR ENABLED TRIP.

Fig. 17 - ALAR Level Options

LATCH - makes each relay only again deactivate after the alarm condition has passed, with the acknowledgment of an alarm condition by the operator: pressing the UP key, when it is displayed the process variable in normal operating mode, until it reaches the desired relay, and then press ENTER. If there is no alarm condition for this relay, it will change state. Keep pressing the UP key to return to the operating mode. Note that only appear relays configured with latch and only if they need acknowledgment to return to normal.

DELAY - causes the relay to be activated only after a certain time interval defined by the user. Figure 18 below illustrates the delay operation for a high-alarm. If the trip function is enabled, you must set this value to 5.0 seconds to temperature input, 2.0 seconds to current input 4-20 mA or 1-5 V voltage.

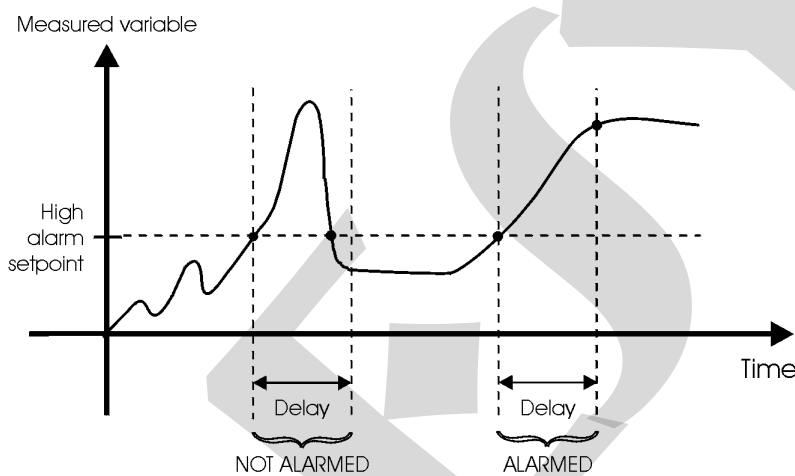

Fig. 18 - Relay with delay

SAFE - determines the security condition to relays. The security condition to relays means that their coils are energized in no-alarm condition, and are de-energized in alarm condition or in case of power failure. If the trip function is enabled for alarm 3 or 4, configure SAFE as NO.

DISP - allows a flashing display indication (set BLINK) or switch the indication with the mnemonic ALAR (set ALAR), when the instrument enters into alarm condition. To disable the DISP option set NO.

Below is the adjustable range of the parameters shown in Figure 17.

| Mnemonic | Parameter | Adjustable Range | Factory Value | Units |
|----------|--------------------------------|------------------|---------------|-------|
| SP | alarm set point | -1009 to 20019 | 50.0 | EU |
| HYST | alarm hysteresis | 0 to 250 | 1.0 | EU |
| DELAY | delay for deactivate the relay | 0.0 to 3000.0 | 0.0 | s |

When the ALAR option is enabled in the GENERAL level, the user can review or change the alarm setpoint values in the normal operating level. The alarm setpoint mnemonics and the fail alarm mnemonics (the latter are shown only to indicate that the alarms are enabled) are explained according to the examples below:

| Mnemonic | Description |
|----------|----------------------------------|
| SP1.Hi | High-alarm set point for relay 1 |
| SP1.Lo | Low-alarm set point for relay 1 |
| SP1.FI | Fail-alarm set point for relay 1 |
| SP2.Hi | High-alarm set point for relay 2 |
| SP2.Lo | Low-alarm set point for relay 2 |
| SP2.FI | Fail-alarm set point for relay 2 |
| SP3.Hi | High-alarm set point for relay 3 |
| SP3.Lo | Low-alarm set point for relay 3 |
| SP3.FI | Fail-alarm set point for relay 3 |
| SP4.Hi | High-alarm set point for relay 4 |
| SP4.Lo | Low-alarm set point for relay 4 |
| SP4.FI | Fail-alarm set point for relay 4 |

Level 7 - Output

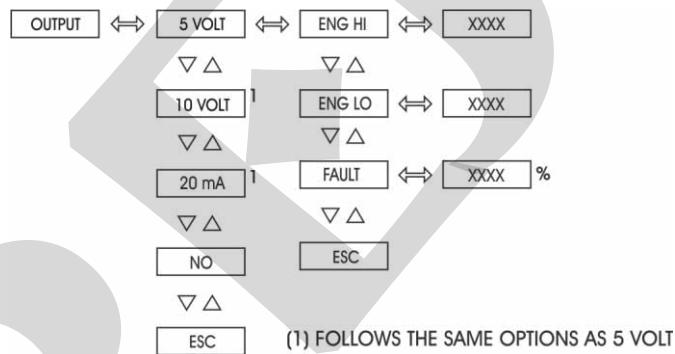

Fig. 19 - Output Level Options

Below is the adjustable range of the parameters shown in Figure 19:

| Mnemonic | Parameter | Adjustable Range | Factory Value | Unit |
|----------|---|------------------|---------------|------|
| ENG LOW | display indication associated to the output zero scale | -1009 to 20019 | 0.0 | EU |
| ENG HIGH | display indication associated to the output full scale | -1009 to 20019 | 100.0 | EU |
| FAIL | output signal in case of sensor break and input (RTD, TC, 4-20 mA or 1-5 V) | 0 to 105 | 15 | % |

Select the range of the retransmission output for 4-20 mA, 1-5 V or 0-10 V. Defining two points as shown in Figure 20. Low Eng is the display indication in engineering units associated with the scale of zero (1 V for the 5 V output, 0 V for the 10 V output and 4 mA for the 4-20 mA output) of output range and Eng High is the display indication in engineering units associated with the full scale (5 V for the 5 V output, 10 V for the 10 V output and 20 mA for the 4-20 mA output) of the output range.

The Analog Output board should be installed in connectors CN1 and CN2 of CPU board and have their jumpers properly arranged: no jumpers for 4-20 mA output, jumper 1 for 1-5 V output and jumper 2 for 0-10 V output.

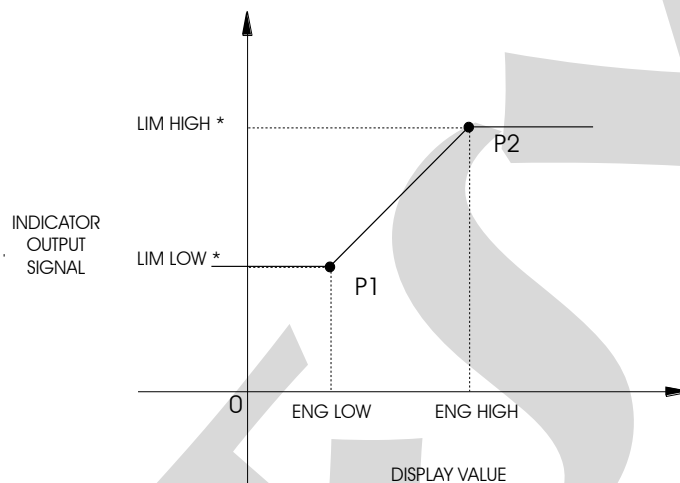

Fig. 20 - Analog Output Configuration

In FAIL parameter, you can set the output to generate a fixed safety value in case input sensor breaking (RTD, TC, 4-20 mA or 1-5 V). For current 4-20 mA or 1-5 V voltage input is considered sensor breaking when the input is lower than 3 mA or 0.75 V (for LIM.LOW \geq 20.0 %) or higher than 21 mA or 5.25 V. The value set to FAIL is given in percent of output full scale (% FS), with an allowable range of values 0 % to 105 %. For example, if the output is 4-20 mA and FAIL = 15%, output assumes the value of 3 mA when input sensor breaking is detected.

Level 8 - Calibration

Level 8 is described in section 4.4 Calibration.

4.0 - Maintenance

4.1 - Hardware

The indicator maintenance requires that the user has access to the instrument hardware. The indicator hardware is divided into three main boards: Display Board, CPU Board and Power supply board. The set of the three boards is attached to the aluminum case by only one screw on the right side of the front panel. Loosen this screw and pull the front panel display to remove the instrument from the case.

The display board is located on the front indicator panel. The front panel has four inner tabs located in the four corners that hold together the CPU Board and the Power Supply Board. A bolt spacer between the CPU and the Power Supply board is still placed to give greater rigidity to the set. To open the set follow the instructions below:

- i) Remove the screw that fixes the spacer located at the bottom of the boards.
- ii) Turn the indicator so that the display becomes opposed to the sense of reading.
- iii) Release only the tab in the upper right corner of the front panel.
- iv) Release the upper board to the right and open the boards as shown in Figure 21.

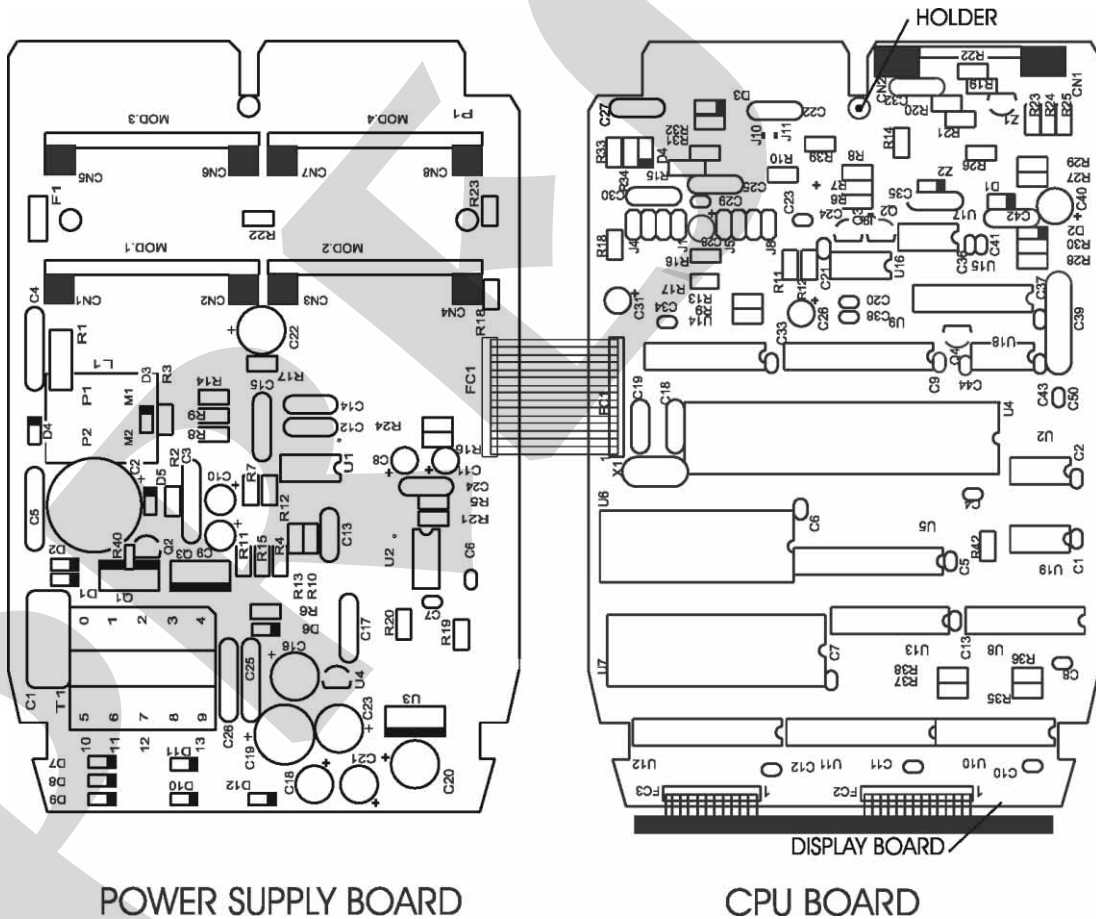

Fig. 21 - Indicator Hardware

4.2 - Using snubber with relays

Relay modules are provided with circuits for eliminating electrical arch (RC snubber). The snubbers can be put in parallel with the relay contacts, by placing the jumpers J1 and J2 localized on the back of the relay board. When the jumpers are not placed, the relay contacts are kept without snubbers. The relay module is sent from factory with the jumpers not placed.

Note the position of the jumpers in the following figure. The jumpers may be localized on the front or the back side of the board, depending on its version.

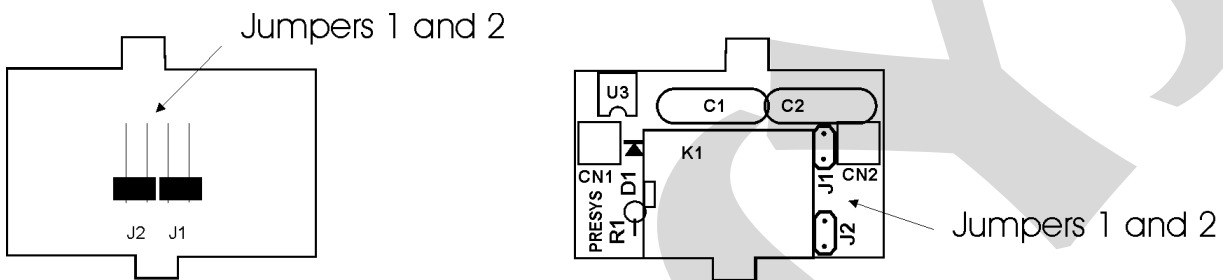

Fig. 22 - Jumpers for selection of snubbers on the relay board

Alarm and control relays are extremely critical in control and safety of industrial processes. In order to ensure the expected relay behavior, consider the following two loading conditions.

- High currents circulating through the relay contacts (from 20 mA to 3 A). When the relay switches high currents there is the occurrence of electrical arch which damage quickly the relay contacts. Besides, electrical noise is generated. In these conditions, it is recommended to use the RC snubbers which come with the relay module (placed jumpers).
- Low currents circulating through the relay contacts (less than 20 mA). The relays could not function properly when the jumpers are placed. In this case, the snubbers maintain a 4.5 mAac/9.0 mAac current when connected to a 120 Vac/220 Vac circuit. This current is enough, in certain cases, to power a horn or alarm lamps, preventing their deactivation. In this situation, there is no need to use the snubbers and the jumpers must be removed.

Note: If your relay module board does not have the mentioned jumpers, is because it belongs to an older version. Apply it for the same reasons explained above regarding the use of RC snubber. However, in this case, to remove the snubber, it should remove the two capacitors of 0.1 x 250 V μ F located above the relay.

4.3 - Optional Modules Installation

The DMY-2030-Light-5S-Energy indicator can have up to four alarm outputs and one analog output. This requires that the corresponding optional modules are installed inside the unit. Open the indicator as shown in section 4.1 in order to access the four connectors on the Power Supply Board, plus a connector on the CPU board (see Figure 23).

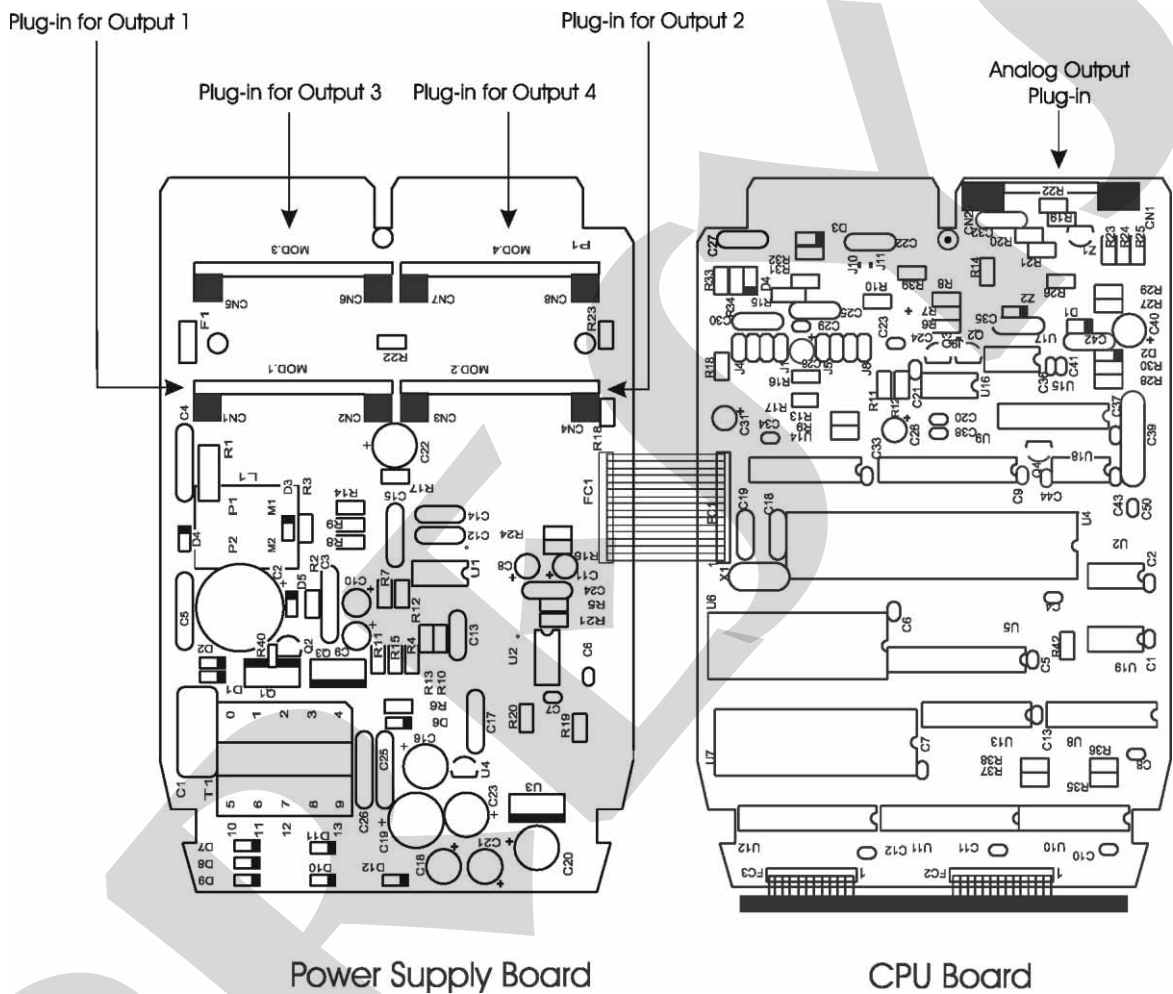

Fig. 23 - Optional modules Plug in

The connectors on the Power Supply board are called MOD 1, MOD 2, MOD 3 and MOD4 and correspond respectively to outputs 1 to 4 at the indicator terminals shown in Figure 3. The connectors of the analog output are located on the CPU board and have no denomination. Any optional module must always be installed with their components directed towards the display board, as illustrated in Figure 24.

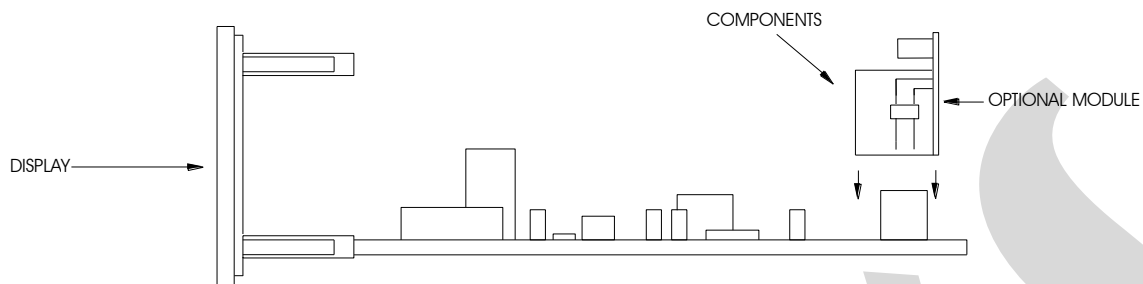

Fig. 24 - Optional Modules Installation

Retransmitter Output (Option Module code: MSAN-20X)

To make use of retransmitter output (4-20 mA, 1-5 V or 0-10 V) connect the optional analog output module in CN1 and CN2 connectors available on the CPU board.

The optional analog output module has two installation jumpers: J1 and J2, as shown in Figure 25.

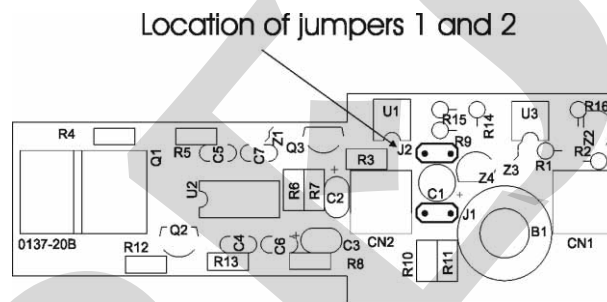

Fig. 25 - Location of the jumpers on the analog output board

To configure the analog output optional module for retransmission output 4-20 mA, 1-5 V or 0-10 V just install the jumper as specified in the table below:

| Retransmission Outputs Types | Jumpers | |
|------------------------------|---------|----|
| 4-20 mA* | | |
| 1-5 V | J1 | |
| 0-10 V | | J2 |

(*) In case of retransmitting output 4-20 mA current, you should save the provided jumper off the instrument or put it on only in one connector pin to not jumper the connectors.

Outputs 1 and 2 - With alarm outputs

The outputs 1 and 2 work as alarms when connected to the corresponding optional module MOD1 and MOD2 slots, respectively. There are three possible types of alarm output: SPST relay, solid state relay and open collector voltage. The relationship between the alarm output type and the corresponding optional module is established in the table below.

| Alarm Output Type | Optional Module Code |
|--------------------------|-----------------------------|
| SPST Relay | MALRE - 20 |
| Solid State Relay | MALRS - 20 |
| Open Collector Voltage | MSD - 20 |

Outputs 3 and 4 – With alarm outputs

The outputs 3 and 4 work as alarms when connected to the corresponding optional module MOD3 and MOD4 slots, respectively. There are three possible types of alarm output: SPDT relay, solid state relay and open collector voltage. The relationship between the alarm output type and the corresponding optional module is established in the table below.

| Alarm Output Type | Optional Module Code |
|--------------------------|-----------------------------|
| SPDT Relay | MALRE - 20 |
| Solid State Relay | MALRS - 20 |
| Open Collector Voltage | MSD - 20 |

4.4 - Calibration

Warning: Only enter the following options after understand perfectly all steps. Otherwise, it may be necessary to return the instrument to the factory for recalibration. Calibration in this manual means adjustment.

DMY-2030-Light-5S-Energy Indicator is accurately calibrated in factory and does not need periodic calibration in normal conditions. When calibration is required, follow the procedure below:

- Disconnect the process signals of I/O terminals.
- Before calibrating the instrument, keep it turned on for at least 30 minutes to warm up.

This section basically consists of two parts: input calibration and output calibration.

Input Calibration

The accuracy of the standard for calibration, to generate references, should be at least twice as good as the specifications of the indicator. The references relate to the type of input to be calibrated given in the following tables. In the right column of these tables are the mnemonics shown on the display in the calibration process.

Before starting the calibration you need to enter at level 8 Calibration. The calibration level has a password system that prevents inadvertently entries in this level and changes in the indicator calibration parameters. **The password to enter the calibration level is the number 5.**

Once satisfied the calibration password, select the type of input to be calibrated within the option INPUT. The display shows the corresponding mnemonic to the references required for the calibration process references should be put before the appearance of the corresponding mnemonic on the display and the calibration starts by pressing ENTER. At this moment the indicator enters the calibration process with the display blinking the mnemonic CAL.

While the display is blinking the reference must remain connected to the input. When the display stops blinking and returns to the corresponding mnemonic, the calibration process of the first point is finished.

Switch to the next reference and press DOWN to select the next point. Between any two calibration points always wait 1 minute. After this time, press ENTER to start the calibration of this point.

After finished all the references in the table on the type of input to be calibrated, the calibration process is complete.

You can redo the calibration of only one without affecting the other points already calibrated if the calibration of this point was not well done.

To return to normal operation back the hierarchical levels to zero level.

Figure 26 shows the calibration input and output options for the level 8 - Calibration.

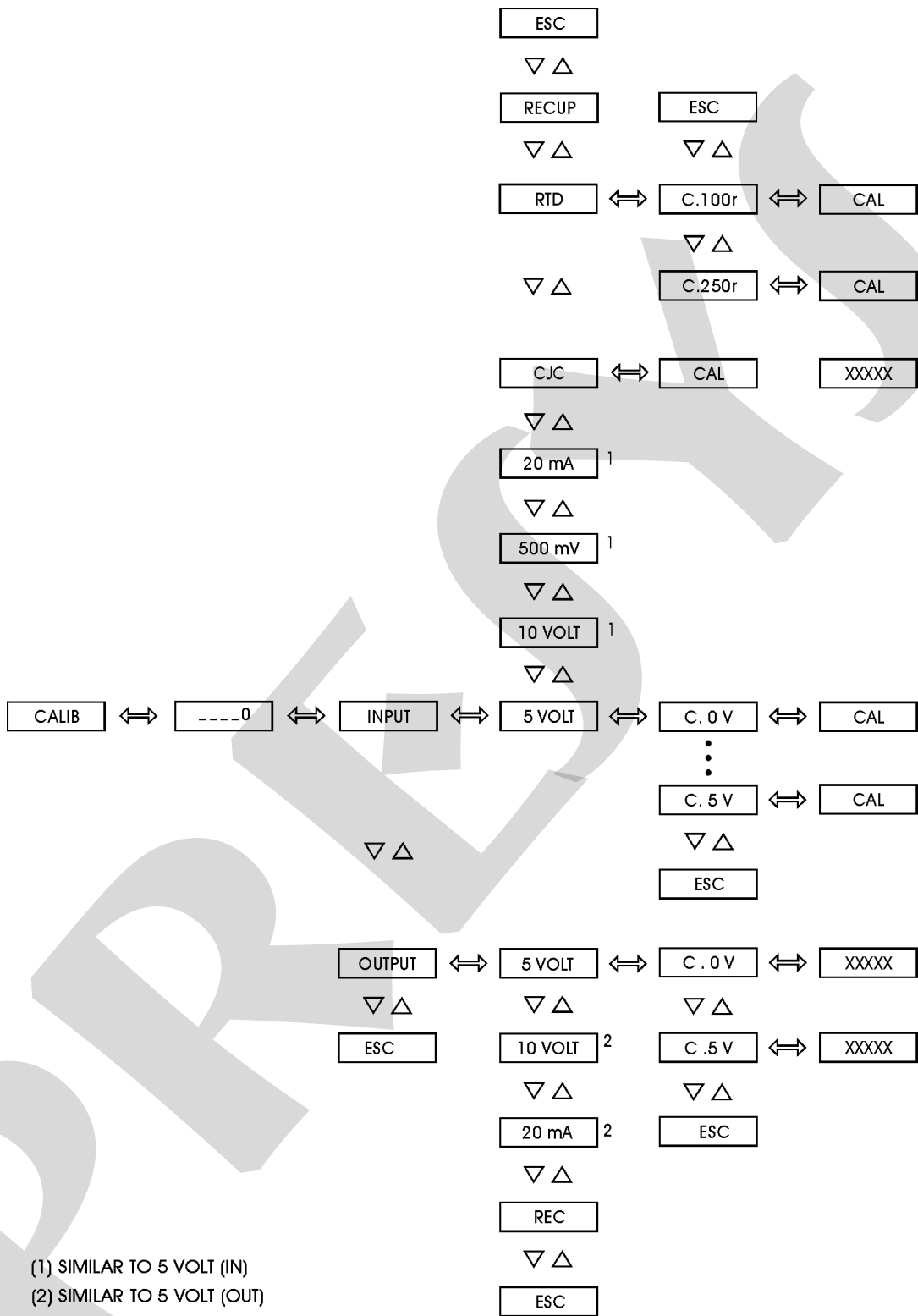

Fig. 26 - Calibration Level Options

Voltage input calibration (0 to 500 mV)

To calibrate the voltage input from 0 to 500 mV connect a DC precision voltage source to terminals 2(+) and 3(-). Are required 6 voltage references listed in the table below.

| Reference | Mnemonic |
|-----------|----------|
| 0.000 mV | C. 0nV |
| 100.00 mV | C.100nV |
| 200.00 mV | C.200nV |
| 300.00 mV | C.300nV |
| 400.00 mV | C.400nV |
| 500.00 mV | C.500nV |

Voltage input calibration (1 to 5 V)

To calibrate the voltage input from 1 to 5 V connect a DC precision voltage source to terminals 2(+) and 3(-). Are required 6 voltage references listed in the table below:

| Reference | Mnemonic |
|-----------|----------|
| 0.0000 V | C. 0V |
| 1.0000 V | C. 1V |
| 2.0000 V | C. 2V |
| 3.0000 V | C. 3V |
| 4.0000 V | C. 4V |
| 5.0000 V | C. 5V |

Voltage input calibration (0 to 10 V)

To calibrate the voltage input from 1 to 5 V connect a DC precision voltage source to terminals 4(+) and 6(-). Are required 6 voltage references listed in the table below:

| Reference | Mnemonic |
|-----------|----------|
| 0.0000 V | C. 0V |
| 2.0000 V | C. 2V |
| 4.0000 V | C. 4V |
| 6.0000 V | C. 6V |
| 8.0000 V | C. 8V |
| 10.0000 V | C.10V |

Current input calibration (4 to 20 mA)

To calibrate the current input from 4 to 20 mA connect a DC precision current source to terminals 5(+) and 6(-). Are required 6 current references listed in the table below:

| Reference | Mnemonic |
|-----------|----------|
| 0.000 mA | C. 0nA |
| 4.000 mA | C. 4nA |
| 8.000 mA | C. 8nA |
| 12.000 mA | C.12nA |
| 16.000 mA | C.16nA |
| 20.000 mA | C.20nA |

You can then return to normal operating mode down until the level zero.

Thermocouple input calibration

The thermocouple input calibration occurs in two steps. First proceeds calibrating inputs 0-500 mV and 0-5 V as detailed by the tables above. After make mV calibrations, access the CJC mnemonic within the ENTR option in calibration level 8 (see Figure 26).

CJC - is the corresponding mnemonic to the cold junction temperature.

Pressing ENTER after the mnemonic CJC the program automatically starts to calculate the temperature of the cold junction. During this time the display blinks the mnemonic CAL.

After 16 seconds the program finishes the calculation of the cold junction temperature and the presents the value on display in °C.

This value is a first approximation of the cold junction temperature. The user should accurately measure the temperature of the terminal block and enter the value presented by the program in the usual way to enter parameter values explained in 3.2 Configuration section.

Finished these two steps of the calibration input for any type of thermocouple is completed.

You can then return to normal operating mode down until the level zero.

3-wire RTD input calibration

For the 3-wire RTD input calibration connect precision resistors in the values listed in the table below between terminals 1 and 2 with short circuit between terminals 2 and 3.

In the case of having a precision decade, ensure that the three connecting wires have exactly the same length, gauge and material.

| Reference | Mnemonic |
|-----------|----------|
| 100.000 Ω | C.100r |
| 250.000 Ω | C.250r |

Output Calibration

The retransmitter output is calibrated with the help of the indicator itself.

Check if the setting of the internal jumper of the Optional Analog Output Board is in accordance with the type of output (without jumpers for the 20 mA output, jumper 1 for 5 V and jumper 2 for 10 V).

Make sure that the type of input to be used in the calibration of output is already well calibrated.

Make connections listed in the table below depending on the type of output you want to calibrate.

| Output Type | Connection between Output and Input |
|-------------------|--|
| current (4-20 mA) | terminal 8 (+) with 5 (+) terminal 9 (-) with 6 (-) |
| voltage (1-5 V) | terminal 8 (+) with 2 (+) terminal 9 (-) with 3 (-) |
| voltage (0-10 V) | terminal 8 (+) with 4 (+) terminal 9 (-) with 6 (-) |

Enter the calibration level 8, select the type of output (4-20 mA, 1-5 V or 0-10 V) and press ENTER. The display will show the corresponding mnemonic to the first calibration point. There are only two output calibration points.

In the case of current output the mnemonics correspond to electrical signals of 0 and 20 mA. For the voltage output, the signals correspond to the mnemonics of 0 and 5 V or 0 and 10 V.

Pressing ENTER after the exhibition of the corresponding mnemonic to the first or second calibration point the display goes on to show the output value.

You can then through the UP and DOWN keys to adjust the output value for the electric level presented by mnemonics. After adjusted, press the ENTER key.

In the first calibration point (0 mA, 0 V) must be careful not to saturate the output signal.

You can then return to normal operating mode down until the level zero.

Return to factory calibration

The indicator remains in the non-volatile memory values of the factory calibration parameters which can be retrieved at any time.

When it is suspected that an instrument malfunction is due to a recalibration badly done should make use of RECOVERY option (see Figure 25).

REC - is the option that allows the recovery of the factory calibration values. It is an option both for input and output.

Enter the level 8 Calibration and choose whether the recovery should be performed for the input or the output. Select the RECOVERY option and press ENTER to reload the factory configuration

4.5 - Hardware Maintenance Instructions

Before returning the instrument to the factory, check the following causes of an apparently defective indicator.

Instrument with error indication on the display

After turning the instrument on, it tests RAM and E2PROM integrity.

When at least one of these components presents some problem the display shows the following error codes:

Err. 01 - RAM error

Err. 02 to Err.04 - E2PROM error

In case of RAM error, turn the instrument off and on to check if the error message is displayed again. If the error remains, return the instrument to factory.

When there is E2PROM error, press the ENTER key and configure the instrument again. Turn the instrument off and on to check if the error message is displayed repeatedly. If the error remains, return the instrument to factory.

Instrument with the display off

Check if power supply voltage is provided to terminals 23 and 24 of the Indicator.

Verify the integrity of fuse F1 of 2.0 A placed in the Power Supply Board as shown in Figure 20. Due to its package it is necessary to check the fuse continuity in order to detect if it is broken.

Instrument malfunction

Check that the indicator is configured correctly both in terms of software and hardware (internal jumpers for the output).

Check that the optional modules are installed at the right places.

Check if the voltages on flat cable 1, as shown in Figure 27, are close to the values in table below and if they reach the CPU Board.

| Test points on flat cable 1 | Voltages |
|--------------------------------|----------|
| Between points 1(-) and 2(+) | 5 V |
| Between points 9(-) and 8(+) | 8 V |
| Between points 9(-) and 1(+) | 0 V |
| Between points (-) and 10(+) | -8 V |
| Between points 9(-) and 13(+) | 24 V |
| Between points 12(-) and 11(+) | 5 V |

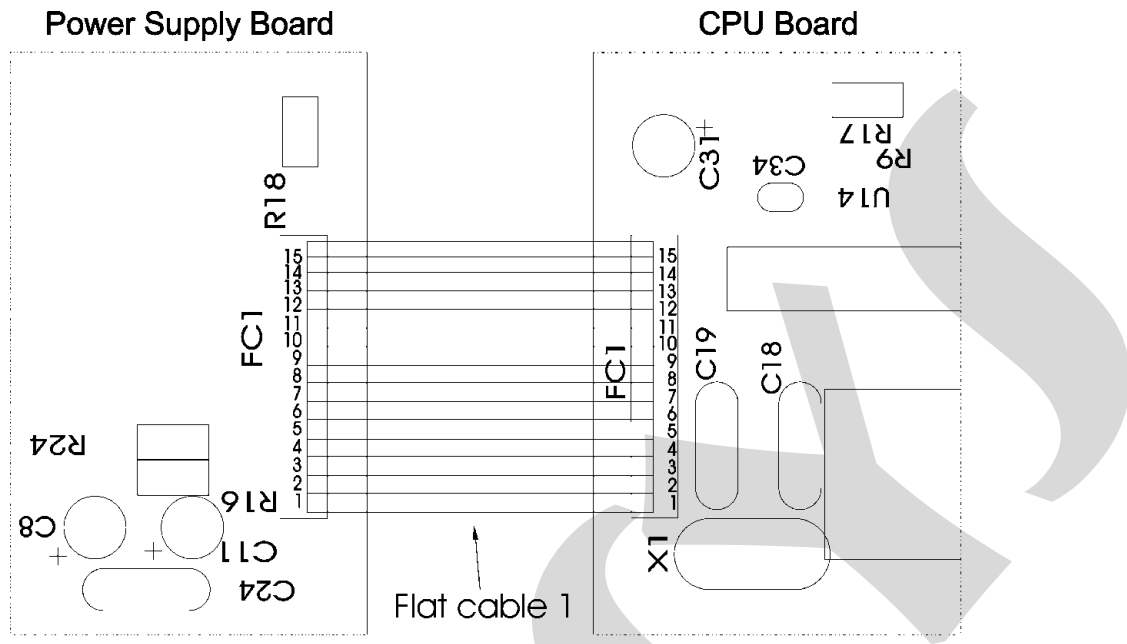

Fig. 27 - Voltage test points of the Indicator

If the cause of the problem is not identified the indicator should be returned to the factory for repair.

PRESTY

PRESTY

PRESTY

PRESYS

www.presyscorp.com
