

DCY-2050 / 2051 / 2060 *Light* Universal Process Controllers

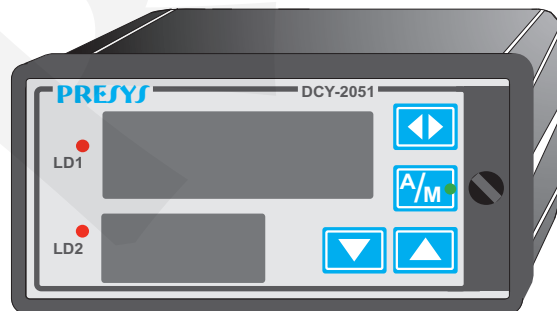
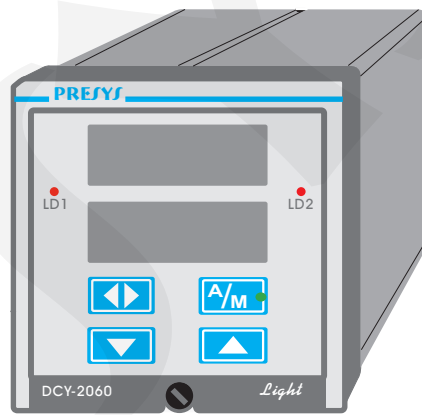
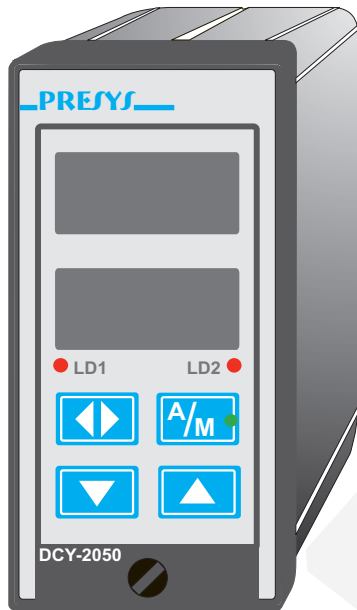

TECHNICAL MANUAL

Índice

1.0 - Introduction	1
1.1 - Description	1
1.2 - Order Code Number	4
1.3 - Technical Specifications	5
2.0 - Installation	8
2.1 - Mechanical Installation	8
2.2 - Electrical Installation	9
2.3 - Process Input Signal Connections	10
2.3.1 - Thermocouple Connection	11
2.3.2 - RTD Connection	11
2.3.3 - Milliampere Input	12
2.3.4 - Voltage Input (mV or V)	13
2.4 - Control and Alarm Output Signal Connection	14
2.5 - Connection Diagram	16
2.6 - Communication	18
2.7 - Engineering Units	18
3.0 - Operation	19
3.1 - Normal Operation	19
3.2 - Configuration	20
3.2.1 - Level 1 - General	22
3.2.2 - Level 2 - Inputs	24
3.2.3 - Level 3 - Output	27
3.2.4 - Level 4 - Alarms	29
3.2.5 - Level 5 - Control	31
3.2.6 - Level 6 - Tune	38
3.2.7 - Level 7 - SetP (Programmable Setpoint)	42
3.2.8 - Level 8 - Calibration	44
3.2.9 - Level 9 - RS	47

1.0 - Introduction

1.1 - Description

The Presys DCY-2050/2051/2060 *Light* Controllers are microprocessor-based instruments which control and show any process variable found in industrial plants, such as: temperature, pressure, flow, level etc. They are provided with two types of non-volatile internal memories (E2PROM and NVRAM) to store configuration and calibration values. Its high accuracy is warranted by auto-calibration techniques based on high thermal stability voltage reference.

The DCY-2050/2051/2060 *Light* Controllers have been designed according to modularity and flexibility concepts. Five plug-in points are provided inside the controllers for the installation of optional modules, with which one obtains a wide variety of control or retransmitter output types (output 1 and 2), such as: relay, open collector voltage, solid-state relay, voltage output (1 - 5V, 0 - 10V) and current output (4 - 20mA). Output 1 is used for control only, while output 2 can be used as a retransmitter output, providing a linear signal related to the process variable measured, or as auxiliary output for heating-cooling control. They can be provided with up to two alarm modules (output 3 and 4) such as relay, open collector voltage and solid-state relay, and they can communicate with a computer by means of a RS-232 or RS-422/485 optional communication module.

The DCY-2050/2051/2060 *Light* Controllers are provided with several control modes (ON-OFF, PID, time proportioning, heating-cooling) and auto-tune algorithm to compute the PID parameters for optimizing control capabilities. They incorporate all standard control characteristics, such as: auto manual bumpless transfer, output saturation, remote setpoint and programmable setpoint up to ten segments, protection against integral saturation, etc.

They are capable of monitoring one universal standard input for measurement of the process variable, accepting direct thermocouple connection, RTD, current (mA_{dc}) and voltage (mV_{dc}, V_{dc}), and a second input of current (mA_{dc}) and voltage (V_{dc}) for remote setpoint. The thermocouple and RTD inputs are automatically linearized by means of tables stored in the EPROM memory. A 24V_{dc} voltage source, isolated and with short circuit protection, is provided for transmitter power supply.

The type of input selected by the user is enabled by jumpers and by the software configuration. All configuration data are protected by a password system, and are stored in the non-volatile memory in case of power failure.

They accept 90 to 240VAC or 130 to 340VDC (with any polarity) power supply.

The equipment has an extruded aluminum case which avoids electrical noise, electromagnetic interference, radiofrequency interference, etc. and its robust construction makes it tough enough for the most hostile environment.

On the front panel of the instruments there are two red displays configurable with decimal point for up to four high visibility digits. The upper display can either show the controlled variable or the L.SP, RE.SP and OUT mnemonics corresponding to the values of local setpoint, remote setpoint and control output shown on the lower display. The control output is presented in percentage of the output full scale. The functions of the UP, DOWN and ENTER keys, for changing the setpoint/output values, are described in section 3.1. The A/M key on the front panel allows to switch between automatic and manual modes. The green led on the A/M key indicates, when turned on, the controllers are in the manual mode and, when turned off, the controllers are in the automatic mode. In the configuration mode of the controllers, both displays show the mnemonics and

values of the parameters. The two red leds can be used as visual alarm indication associated to alarms 3 and 4.

PRESYS

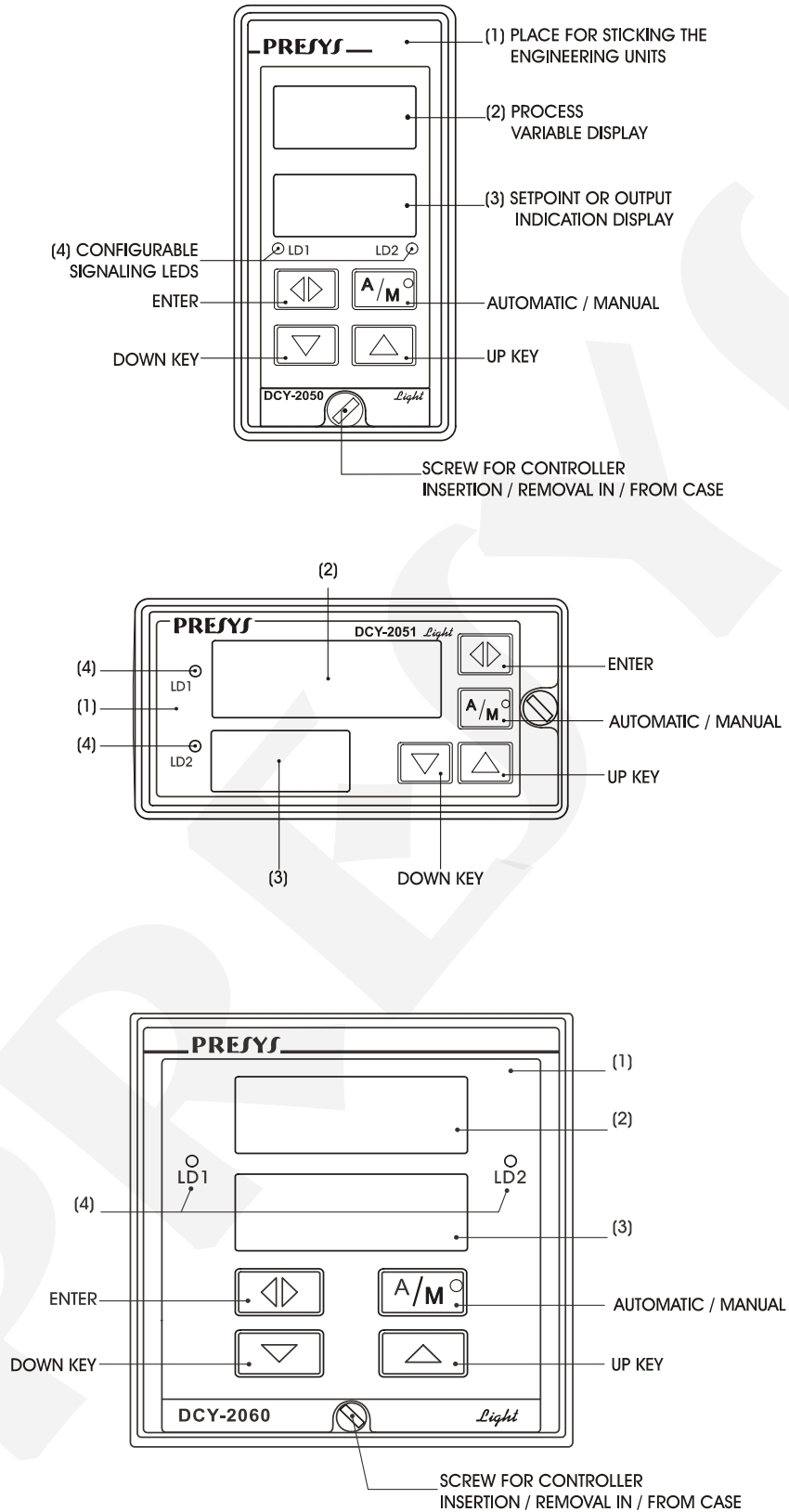
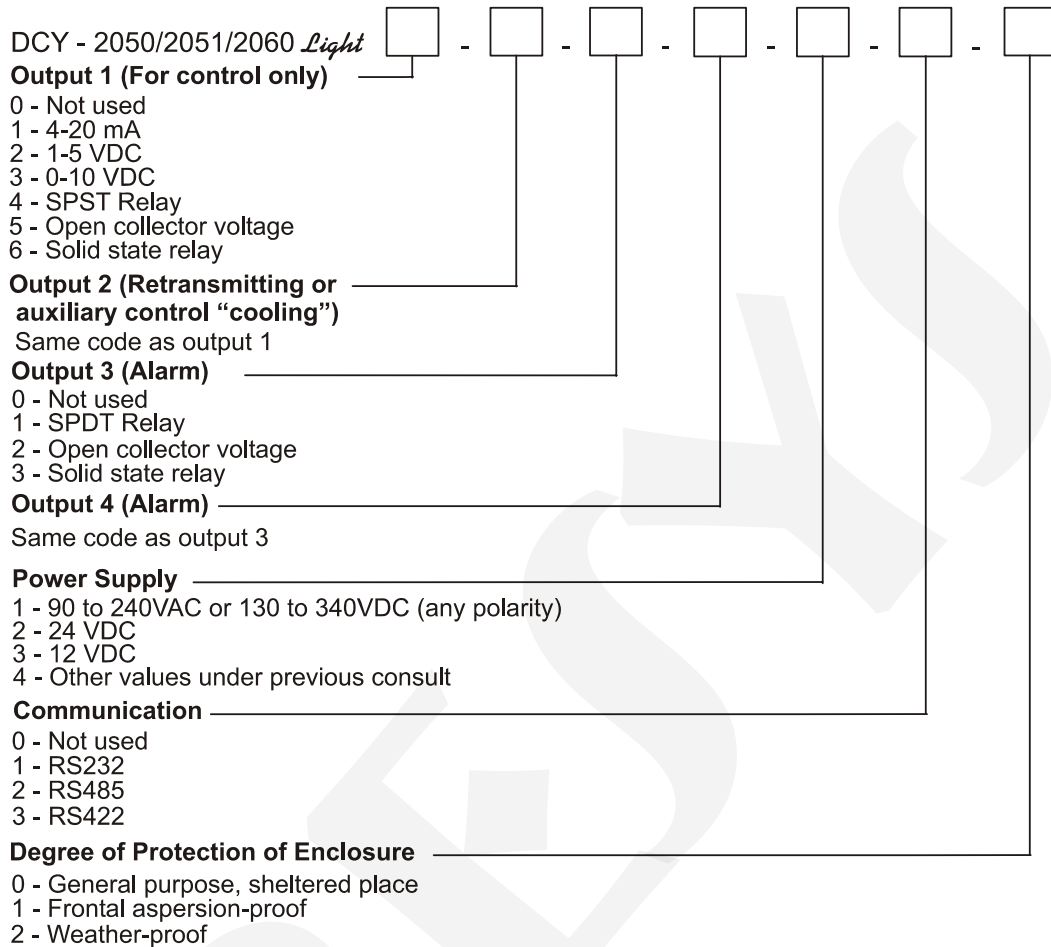

Fig. 1 - DCY-2050/2051/2060 *Light* Controllers Front Panel

1.2 - Order Code Number



Note 1 - The ranges and input types, control algorithms, the indication, the use of relays as alarms and the alarm setpoints are, among others, items which the user may program through the front keys (if wanted, specify these information so that all the configuration can be made by Presys).

Note 2 - Other hardware and software features are available under previous consult.

Code Example:

1) DCY - 2051 - *Light* - 1 - 4 - 1 - 1 - 1 - 0 - 0

This code defines a DCY - 2051 *Light* Controller with output 1 as 4 to 20mA, output 2 with SPST relay, outputs 3 and 4 with SPDT relays. 90 to 240VAC or 130 to 340VDC electric power supply, without communication and for use in a sheltered place. The installation of such optional modules may offer a practical application for heating-cooling control (output 1 heating and output 2 cooling). Outputs 3 and 4 may be used as high, low or deviation alarm outputs.

1.3 – Technical Specifications

Inputs:

- Input 1 configurable as thermocouple (J, K, T, E, R, S, under ITS - 90), Pt - 100 RTD under DIN 43760, 4 to 20mA, 0 to 55mVDC, 1 to 5VDC and 0 to 10VDC. Input 2 configurable as 4 to 20mA, 1 to 5VDC and 0 to 10VDC. Input impedance of 250Ω for mA, 10MΩ for 5VDC and 2MΩ above 5VDC. Table 1 shows the temperature ranges for thermocouples and RTD and the resolution for linear input sensors.

Input Sensor	Measuring Range Limits			
	Lower limit °F	Higher limit °F	Lower limit °C	Higher limit °C
<u>Thermocouple</u>				
J-Type	-184.0	1886.0	-120.0	1030.0
K-Type	-346	2498	-210	1370
T-Type	-418	752	-250	400
E-Type	-148.0	1436.0	-100.0	780.0
R-Type	-58	3200	-50	1760
S-Type	-58	3200	-50	1760
<u>RTD</u> 2 or 3-wire Pt-100	-346.0	1256.0	-210.0	680.0*
<u>Linear</u>	Range		Resolution	
Voltage	0 to 55mV		6μV	
	0 to 5V		500μV	
	0 to 10V		1mV	
Current	0 to 20mA		2μA	

(*) including wire resistance

Table 1 - Measuring ranges for input sensors

Control functions:

- ON-OFF Control
- PID Control
- PID Control with AUTO-TUNE
- Heating-Cooling Control
- Ratio Control
- Remote Setpoint Input
- Programmable Setpoint

Control and retransmitting outputs:

- Analog output 4 to 20 mA DC, 1 to 5 VDC, 0 to 10 VDC, use of optional modules with plug-in fitting for up to two modules, 300 VAC galvanically isolated from inputs and power supply. Maximum load of 750Ω.
- SPST relay output rated 3A 220VAC.
- Open collector voltage output (24VDC, 20mA maximum with isolation).
- Solid-state relay output (2A 250VAC with isolation).

Alarm outputs:

- SPDT relay output rated 3A 220VAC.
- Open collector voltage output (24VDC, 20mA maximum with isolation).
- Solid-state relay output (2A 250VAC with isolation).

Serial communication:

RS-232 or RS-422/485, with 50VDC isolation, as an optional module for connection in the CPU Board.

Indication:

Two red display sets with four digits, configured with decimal point.

Configuration:

By front panel push-buttons and internal jumpers.

Scanning time:

130 ms standard, for input indications within the -999 to 9999 range. Displays updated each 0.5 second.

Accuracy:

- ± 0.1 % of full scale for TC, RTD, mA, mV, Vdc input.
- ± 0.5 % of full scale for analog control output.

Linearization:

± 0.1 °C for RTD and ± 0.2 °C for TC.

Square root extraction:

- ± 0.5 % of reading, for input above 10 % of span.
- Programmable "Cut-off" from 0 to 5 %.

Cold junction compensation:

± 2.0 °C in the range from 0 to 50 °C ambient temperature.

2-Wire Transmitter Power Supply:

24Vdc and 50mA maximum, isolated from outputs, with short-circuit protection.

Stability at ambient temperature:

± 0.005 % per °C of span referred to 25 °C ambient temperature.

Power Supply:

Universal 90 to 240VAC or 130 to 340VDC (any polarity), 10W nominal; 24VDC, 12VDC and other values are optional.

Operating ambient:

From 0 to 50 °C and 90 % maximum relative humidity.

Dimensions:

DCY-2050/2051 <i>Light</i> :	1/8 DIN (48 X 96 mm) with 162 mm depth. Panel cut of 45 X 92 mm.
DCY-2060 <i>Light</i> :	1/4 DIN (96 X 96 mm) with 162 mm depth. Panel cut of 92 X 92 mm.

Weight:

0,5kg nominal.

Warranty:

One year.

PRESYS

2.0 - Installation

2.1 - Mechanical Installation

The front panel of the DCY-2050/2051 *Light* controllers has 1/8 DIN size (48 X 96 mm) and the front panel of the DCY-2060 *Light* controller has 1/4 DIN size (96 X 96 mm).

They are fixed by the rails which press them against the back side of the panel.

After preparing a 45 X 92 mm cut in the panel (92 X 92 mm, for DCY-2060 *Light*), remove the rails from the controller and slide its rear through the cut until its front reaches the panel. Place the rails again in the controller from the back of the panel and tighten the screws as shown in figures 2 and 3.

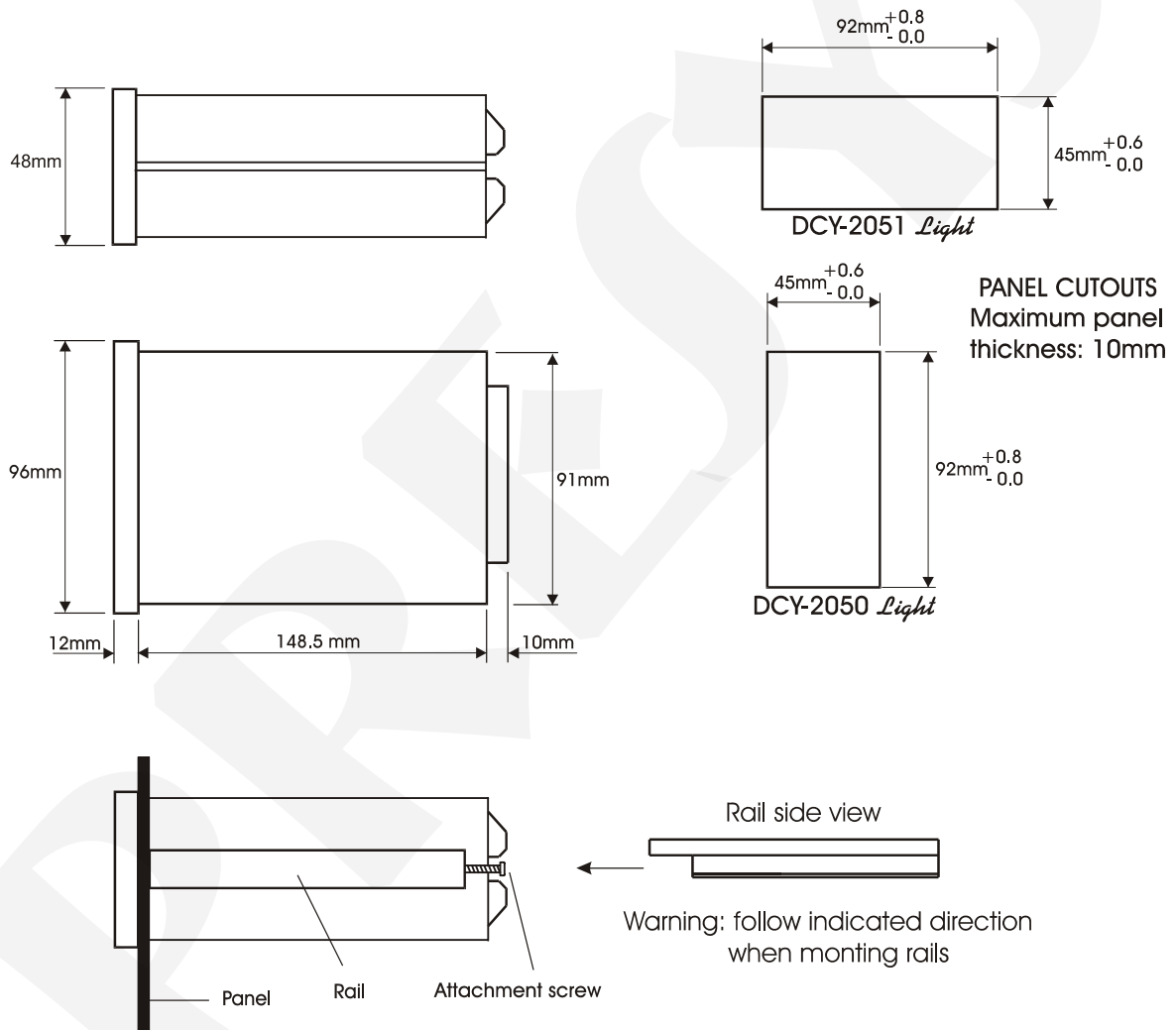

Fig. 2 - Dimensional drawing, panel mounting cutout and side view for DCY-2050/2051 *Light* controllers

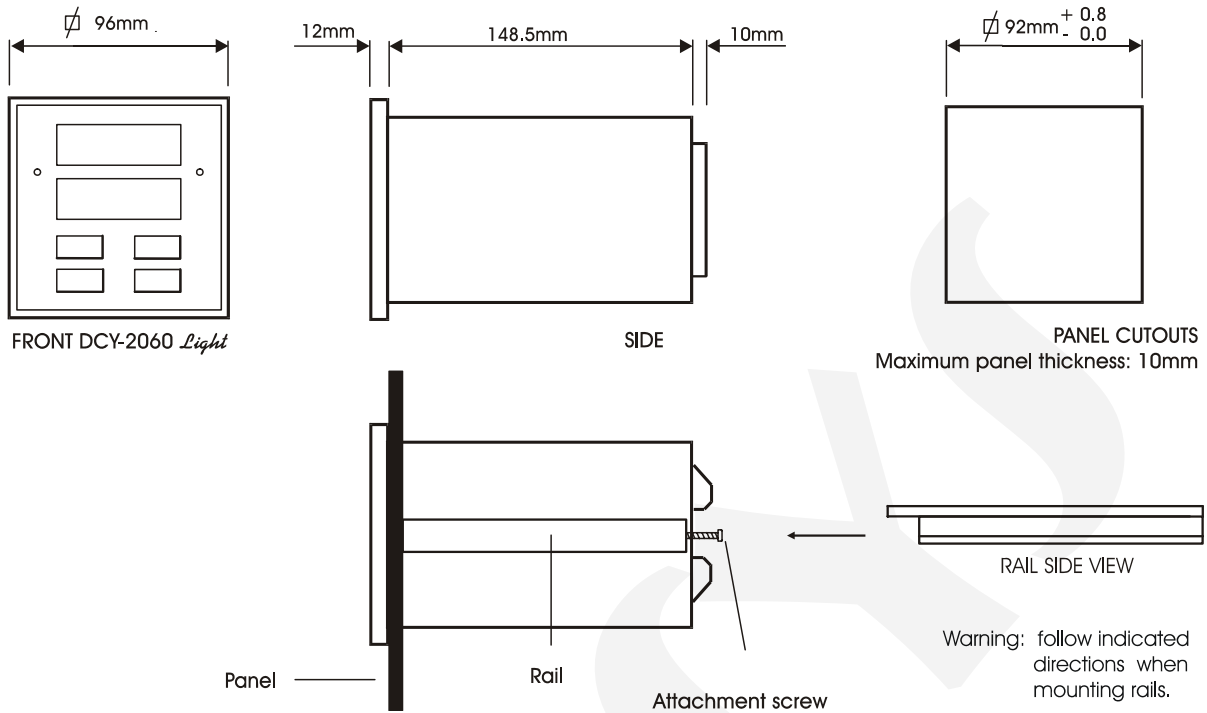

Fig. 3 - Dimensional drawing, panel mounting cutout and side view for DCY-2060 *Light* controllers

2.2 - Electrical Installation

DCY-2050/2051/2060 *Light* controllers may be powered by voltage between 90 and 240VAC or 130 to 340VDC, any polarity. Remember that the internal circuit is powered whenever the instrument is connected to the external power supply.

Input and output signals must be connected to the instrument only when it is turned off.

Figure 4 shows the instrument rear terminals for connection of power supply, ground, communication, process input and output signals.

Signal wiring must be kept far away from power wires.

Due to its metal case the instrument ground should be connected to earth ground. Never connect the ground to neutral terminal.

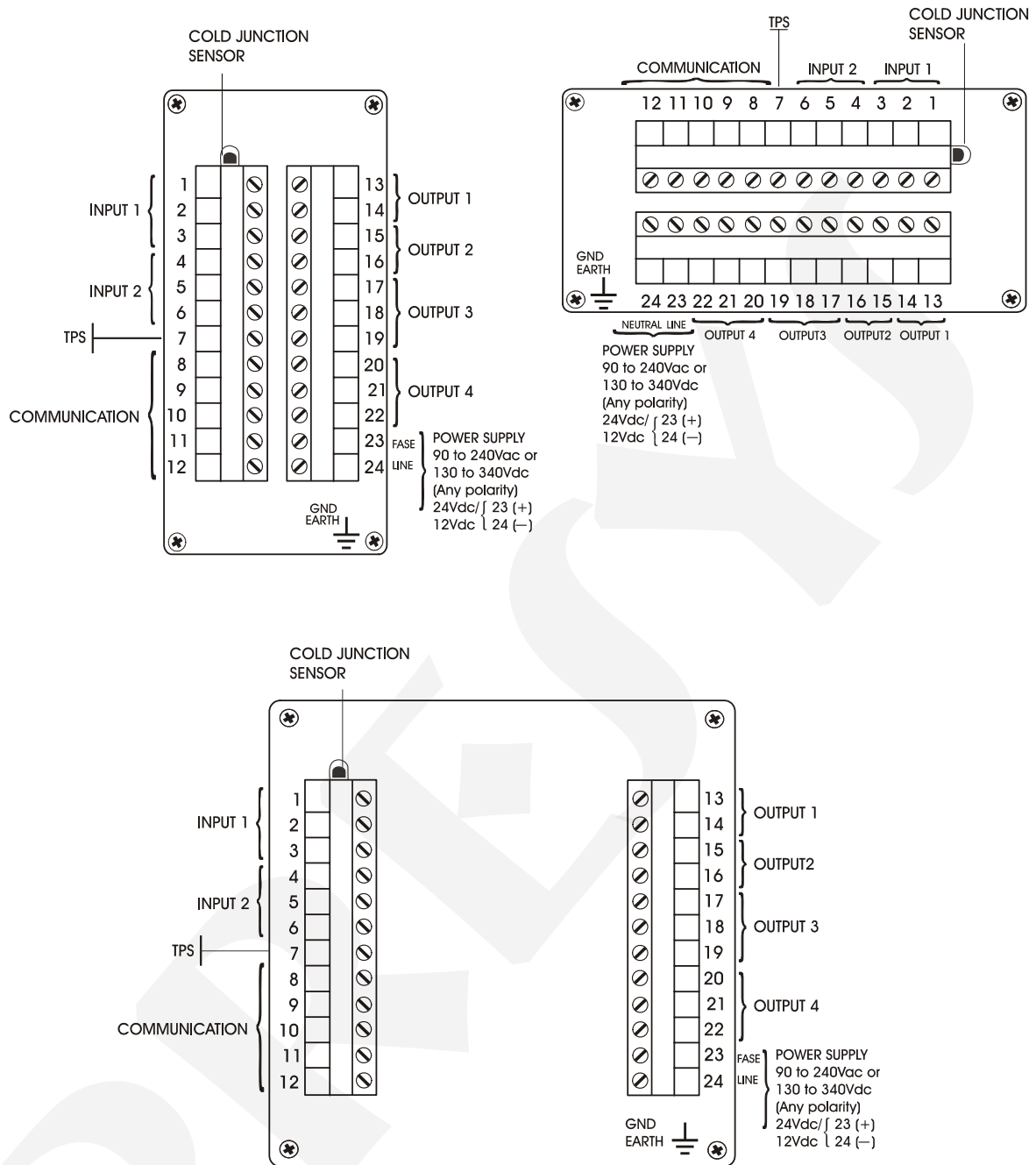

Fig. 4 - DCY-2050/2051/2060 *Light* controller terminals

2.3 - Process Input Signal Connections

The DCY-2050/2051/2060 *Light* controllers accept the connection of thermocouple, 2 or 3-wire RTD, mA, mV or V in input 1, and mA or V in input 2. See the different types and ranges of input sensors in table 1, section 1.3 on Technical Specifications.

A certain type of input sensor is enabled by means of internal jumpers and by the proper sensor selection in configuration mode (refer to section 3.2.2 on

Input). Therefore, the connections explained below shall only become effective if the instrument hardware and software are correctly configured.

The connection of a certain type of sensor in input 1 does not restrict the simultaneous use of a sensor, of the same type or different, in input 2.

In order to avoid noise in the wiring, use twisted pair cable and cross sensor connection wire inside a metallic tube or use shielded cable. Make sure to connect only one shield wire end either to board terminal or to sensor ground, as shown in the next items.

WARNING: GROUNDING TWO SHIELD WIRE ENDS MAY CAUSE NOISE IN THE CONTROLLER.

2.3.1 - Thermocouple Connection

The thermocouple must be used only in input 1, connected to terminals 2(+) and 3(+)

as shown in figure 5. In order to reduce the error due to cold junction compensation, use thermal paste in the rear, at the terminals where the thermocouple is connected to the cold junction sensor. Use appropriate compensating cables with the same material of the thermocouple in order to connect it to the instrument. Check if the thermocouple polarity is equal to those of the terminals.

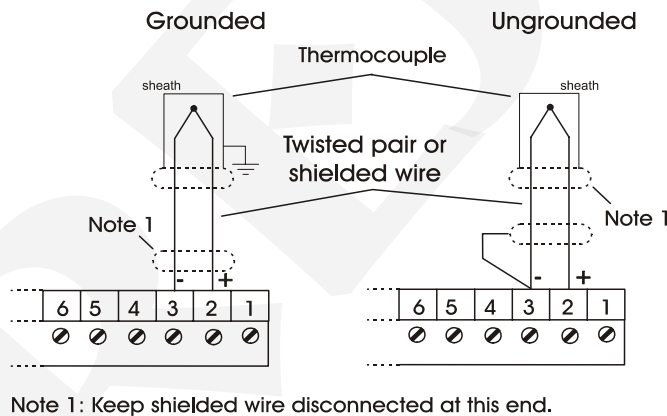

Fig. 5 - Thermocouple Connection

2.3.2 - RTD Connection

Connection is allowed for 2, 3 or 4-wire RTD in input 1. All types of connection are shown in figure 6.

In case of a 2-wire RTD, connect the RTD to terminals 1 and 3 (input 1) as shown in figure 6. For a 3-wire RTD, connect the third wire for RTD compensation to terminal 2. A 4-wire RTD should be connected to the controllers in the same way as the 3-wire RTD, but the fourth wire is left disconnected.

The use of a 3-wire RTD provides a higher accuracy than a 2-wire connection.

The RTD wiring should be of the same material, length and gauge to ensure proper resistance compensation on all terminal connections. The maximum connecting wire resistance is 10 Ω per wire. The minimum wire gauge should be 18 AWG for distances of up to 50 meters and 16 AWG for distances above 50 m.

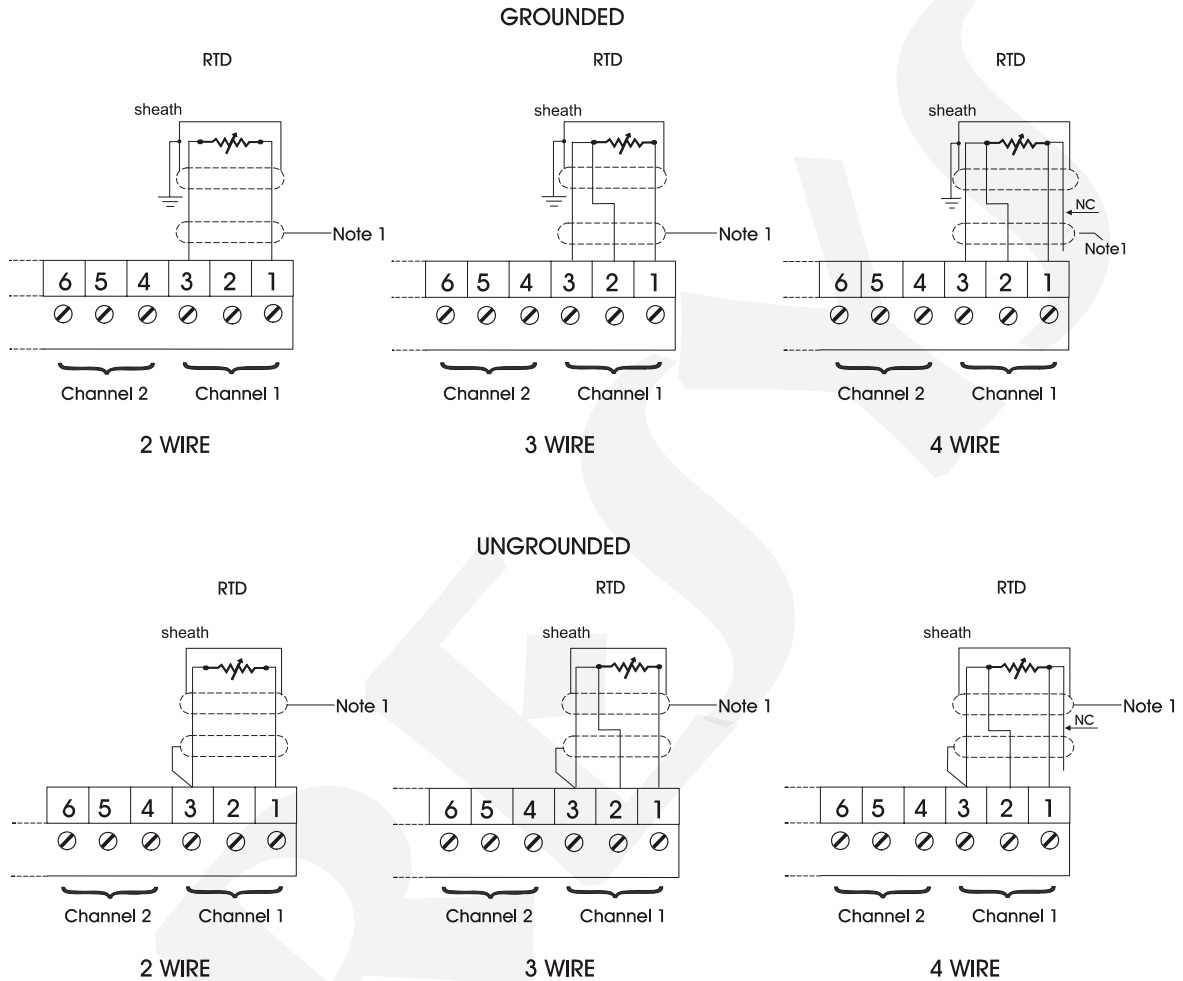

Note 1: Keep the shielded cable disconnected at this end.

Fig. 6 – RTD Connection

2.3.3 - Milliampere Input

A standard 4 to 20mA current source can be applied to terminals 1(+) and 3(-), for input 1, and to terminals 4(+) and 6(-), for input 2. The current can be generated by a transmitter with external power supply. When using the controller internal 24V voltage source to power a 2-wire transmitter, the current is received only by terminal 1(+), for input 1, and by terminal 4(+), for input 2. Figure 7 shows both connection possibilities.

2 - Wire Transmitter

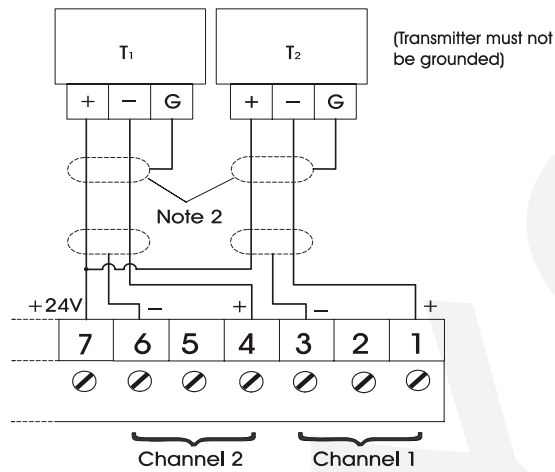

4 - Wire Transmitter

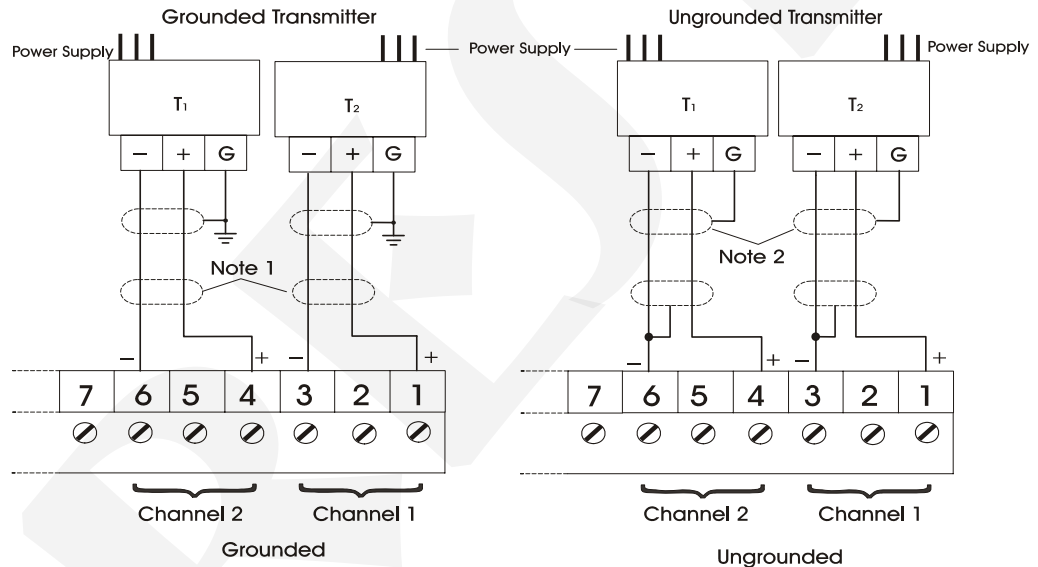

Note 1: Keep shielded wire disconnected at this end.

Note 2: Connect shielded wire to transmitter ground terminal. If there is no ground terminal keep wire disconnected at this end.

Fig. 7 - Current source Connection

2.3.4 - Voltage Input (mV or V)

0 to 5Vdc voltage must be applied to terminals 2(+) and 3(-), for input 1, and to terminals 5(+) and 6(-), for input 2. 0 to 10Vdc voltage must be applied to terminals 1(+) and 3(-), for input 1, and to terminals 4(+) and 6(-), for input 2. 0 to 50mVdc voltage must be applied only to terminals 2(+) and 3(-) for input 1. The connections are shown in figure 8.

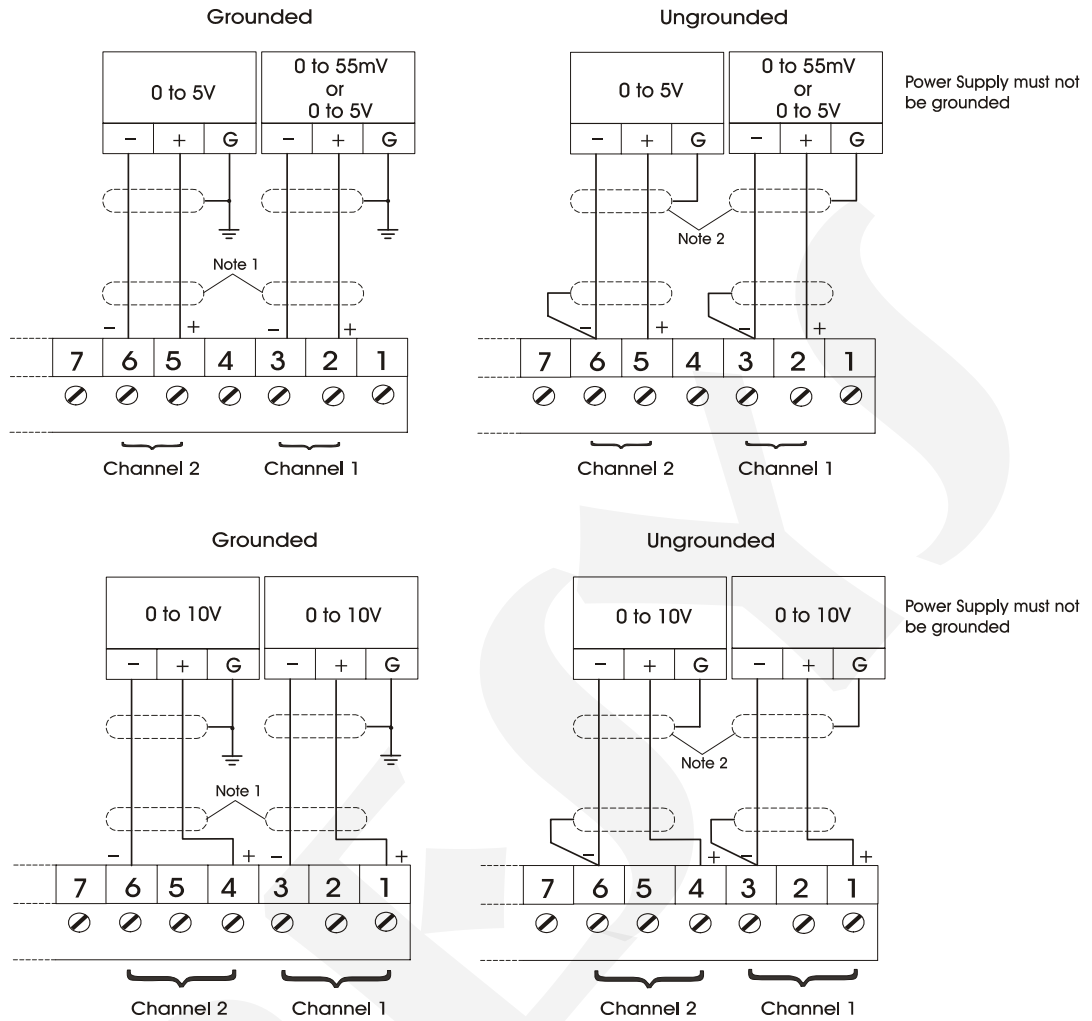

Note 1: Keep shielded wire disconnected at this end.

Note 2: Connect shielded wire to power supply ground terminal. If there is no ground terminal keep shielded wire disconnected at this end.

Fig. 8 - Voltage Source Connection

2.4 - Control and Alarm Output Signal Connection

In most complete versions, the controllers can be provided with up to four output signals. Output 1 is used only as a control output, and output 2 as a retransmitting output or cooling auxiliary control for heating-cooling. Outputs 3 and 4 are used as alarm outputs.

In the case of outputs 1 and 2 we can have six different types of outputs: current (4 to 20mA), voltage (0 to 5VDC, 0 to 10VDC), SPST relay, open collector voltage and solid state relay.

For outputs 3 and 4, there are three different types of outputs: SPDT relay, open collector voltage and solid-state relay. Figure 9 shows the controllers control outputs and figure 10 shows the alarm outputs.

Note that the output terminals will present the signals only if the corresponding optional module is installed and the output is correctly configured (refer to sections 3.2.3 on Output and 3.2.4 on Alarm).

CONTROL MODE	INTERNAL DEVICE	TERMINALS
Current Output Voltage Output Time proportioning Heating ON - OFF		
Current Output (*) Voltage Output (*) Time proportioning (*) Cooling		

(*) Output types also available for output 2 as retransmitting output.

Fig. 9 - Control Output Connections

CONTROL MODE	INTERNAL DEVICE	TERMINALS
Alarm		
Alarm		

(*) For the relay contact positions it is assumed that the controllers are powered on and in no-alarm condition. Without power supply or in alarm condition, contact position changes.

Fig. 10 - Alarm Output Connections

2.5 - Connection Diagram

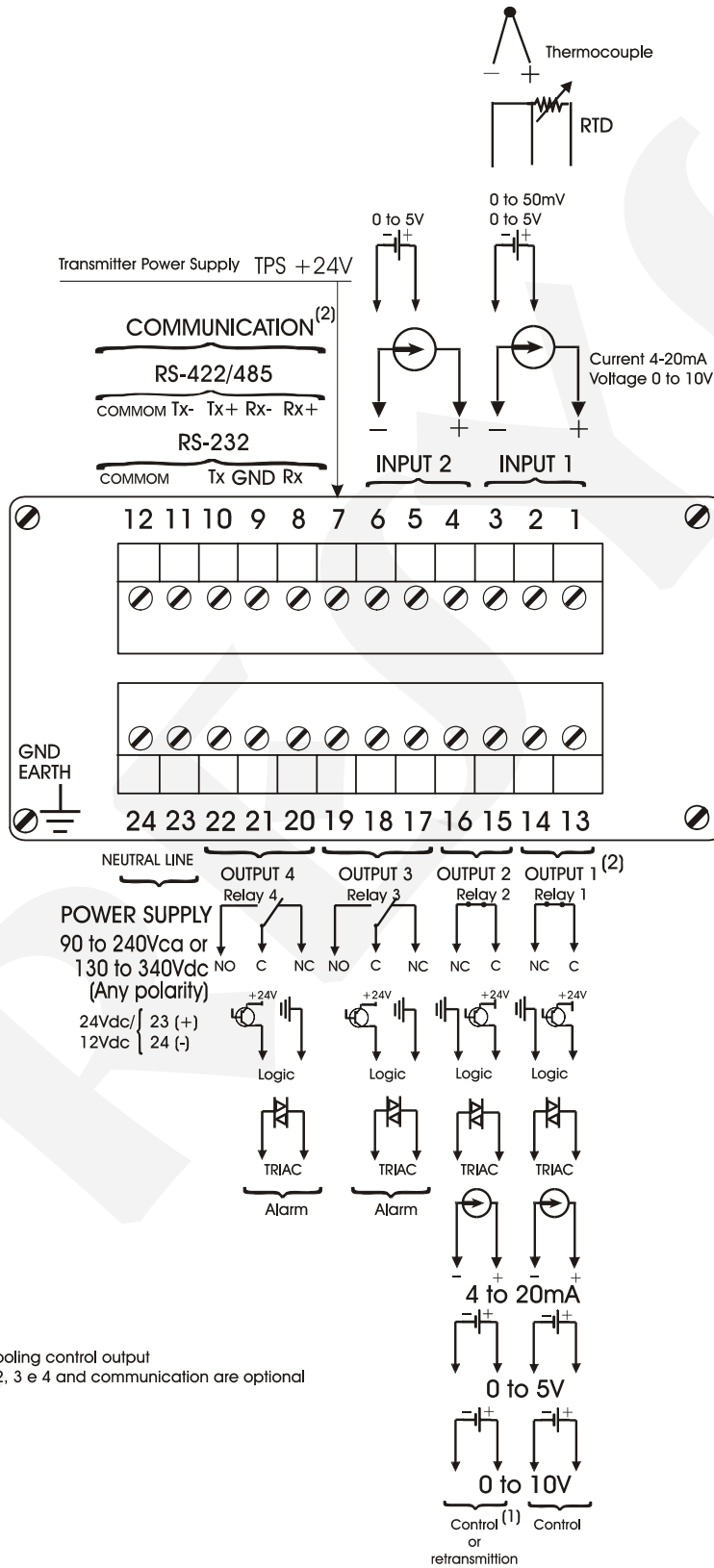

Note:
(1) Auxiliary cooling control output
(2) Outputs 1, 2, 3 e 4 and communication are optional

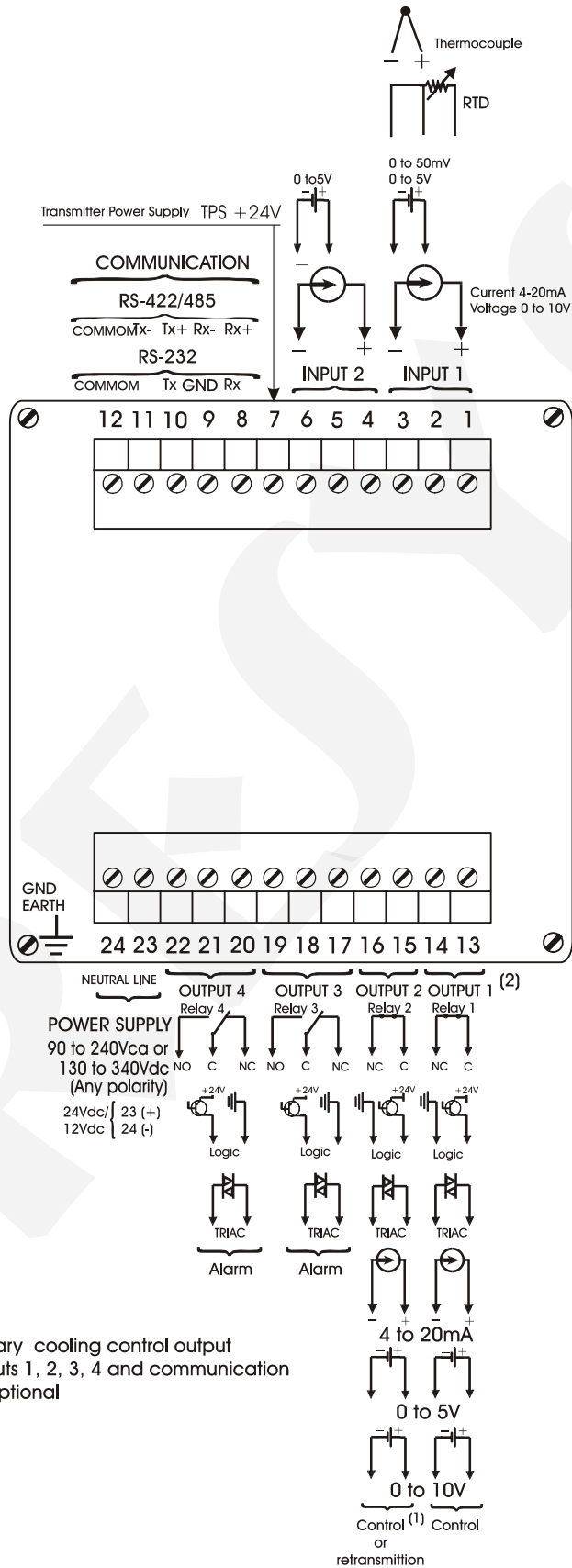

Notes:

- (1) Auxiliary cooling control output
- (2) Outputs 1, 2, 3, 4 and communication are optional

2.6 - Communication

The DCY-2050/2051/2060 *Light* controllers communicate with computers through RS-232 or RS-422/485 and with use of a MODBUS protocol communication software, when the optional communication modules are installed and the communication parameters are configured.

Specific information on communication and signal connection are described in the communication manual.

2.7 - Engineering Units

A label with several Engineering Units is supplied with each instrument. Select the one corresponding to the variable shown on the display and stick it to the front panel of the controller.

PRESYS

3.0 - Operation

3.1 - Normal Operation

The DCY-2050/2051/2060 *Light* controllers present two operation modes: normal operation mode and configuration mode.

In normal operation mode one can have the automatic operation mode and the manual operation mode.





In the automatic operation mode (closed loop system) the controllers receive the input signals, compare them with the setpoints and automatically generate, through control algorithms, the output signals which adjust the input signals to the setpoints.

In the manual operation mode (open loop system) the user establishes the values in output percentage to control the measured variables.

The selection between the automatic and manual modes is done through the automatic/manual (A/M) key on the controllers front panel. When in the manual mode the green LED indicating the manual state is on.

The controllers normal mode, in which they operate most of the time, will be named zero level. In this level the upper display can show: mnemonics for the local setpoint (L.SP) or remote setpoint (RE.SP), control output (OUT), and the value of input 1 (INPUT1). The lower display can show: the value of local setpoint (V_L.SP) or remote setpoint (V_RE.SP), and the value of the control output (V_OUT). Whenever the controllers are turned on, they display indication of the last selection shown, before being turned off. In order to switch to other options, the UP, DOWN and ENTER keys should be used, as illustrated in figure 11.

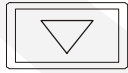
At the operation level, the keys on the instrument front panel have the following functions:

Key		Description
A/M		Switches from automatic mode to manual mode and vice-versa.
UP		Scrolls the display options in ascending order.
DOWN		Scrolls the display options in descending order.
ENTER		Changes the upper display between the mnemonic of the setpoint or output and the value of the variable measured in input 1, as it is shown in fig. 11.

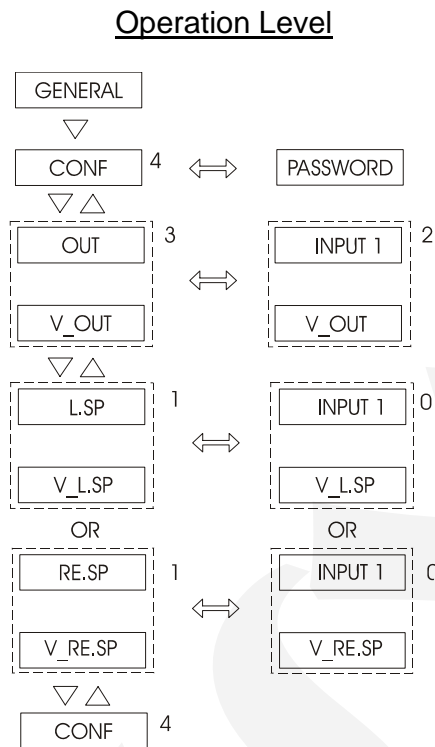

Fig. 11 - Options for Operation Level

The selections on the previous figure are identified by the numbers 0, 1, 2 and 3.

When switching to manual mode (green LED turns on) the configuration selection shifts to type 2. This allows the output to be immediately modified by the UP and DOWN keys. On the other hand, by switching to automatic mode (green LED turns off), the configuration selection changes to type 0. In this case, the setpoint can be immediately altered by the UP and DOWN keys.

3.2 - Configuration

In order to have access to the configuration levels, one has to go through a password system to prevent unauthorized people from altering critical process parameters. Therefore, whenever the key ENTER is pressed, while the mnemonic CONF is shown on the upper display, the password warning (PASS) appears, and the user must press the UP, DOWN and ENTER keys in sequence to enter in the configuration levels. In case the sequence provided by the user is not correct or the PASS mnemonic is shown for more than 15 seconds, the instrument returns to normal operation. This procedure is illustrated in figure 12.

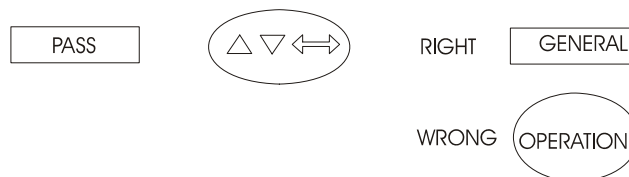

Fig. 12 – Password system

All configuration parameters are stored in the non-volatile memories (E2PROM and NVRAM) and determine the instrument normal operation. Through configuration parameters the user may adapt the instrument according to his requirements, when the configuration from factory must be changed.

The configuration parameters are distributed over nine increasing hierarchical levels as shown in figure 13.

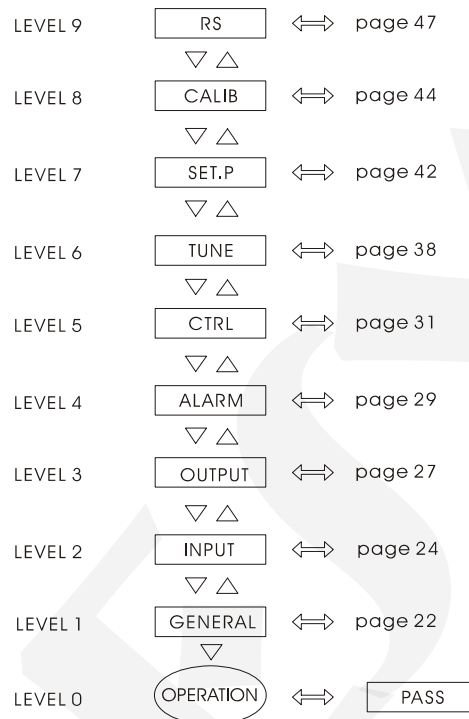

Fig. 13 - Diagram of parameter levels

In order to go through those levels and to have access to their corresponding parameters use the instrument front keys which have the following functions:

Key	Description
ENTER	Enter the level
UP	Switches to a higher level
DOWN	Switches to a lower level

When accessing one of the parameters from a configuration level, the controller shows the option or value corresponding to the current configuration of the parameter.

In the case of presenting a value use the UP and DOWN keys to change each digit and press ENTER to move to the next digit. When configuring a parameter with options, use the UP, DOWN and ENTER keys whose functions are described below:

Key	Description
UP	Scrolls the options in ascending order
DOWN	Scrolls the options in descending order
ENTER	Confirms or advances the options within the level when the display does not show ESC. When ESC is shown on the display, it goes back one or more positions.

The configuration mode presents a “timer” which returns the display to normal operation mode, when no key is pressed after 1 minute. It does not apply when the calibration level (CALIB mnemonic) is accessed (refer to section 3.2.8 on Calibration).

The hierarchical levels are presented below. The options in each level with all the corresponding parameters are explained step by step.

3.2.1 - Level 1 - General

In level 1 we have the options: TAG, V.SFT, SP.Li, PO.BR, ST.CO, LED1 and LED2 (see figure 14).

TAG - this option enables an alphanumeric identification for the instrument. The procedure to enter a tag or any other parameter the user must press ENTER in order to view the value of the parameter with the last digit blinking. The position which is blinking indicates the digit to be changed with the UP and DOWN keys. Move to the digits on the left by pressing ENTER. After entering all digits, press ENTER again.

V.SFT - shows the number of the software version.

SP.Li - this is the option which limits the user selected setpoint between a minimum value (SP.Lo) and a maximum value (SP.Hi).

PO.BR - expressed as a percentage of the output value, it determines the level of output 1 (including output 2 for heating-cooling control) in case temperature sensors (thermocouple and RTD) and linear sensors (55mV, 5V) are broken. Refer also to B.OUT option, on the input configuration level. For linear sensors, the occurrence of a signal lower than (the display indicates UNDER) or greater than (the display indicates OVER) about 10% of the input span makes the output change to manual mode with the output level configured in PO.BR.

ST.CO - this option allows the selection of the mode in which the controllers should return after a power failure. If the mnemonic LAST is selected for ST.CO option, the controller will return to the same configuration (manual or automatic mode) it had prior to the power failure. When the MANL option is selected for ST.CO, the controller will always return in manual mode after a power failure, with the output level determined by the MANL parameter configured by the user.

LED1 and LED2 - they allow the association of LED1 or LED2 on the front panel of the controllers to alarm relay 3 (rly.3) or alarm relay 4 (rly.4).

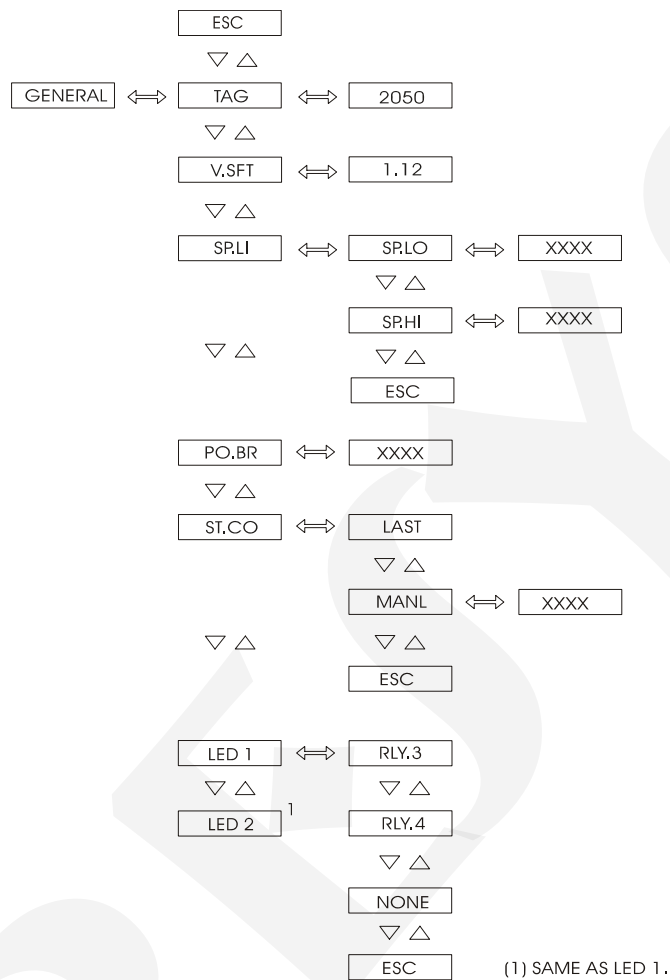

Fig. 14 - GENERAL Level Options

The adjustable parameter ranges shown on figure 14 are given below.

Mnemonic	Parameter	Adjustable Range	Factory Value	Unit
TAG	instrument identification	-----	2050/2051/2060	-----
V.SFT	software version	-----	1.12	-----
SP.Lo	setpoint lower limit	-999 to 9999	0	EU
SP.Hi	setpoint upper limit	-999 to 9999	9999	EU
PO.BR	output power	-100 to 100	0	%
MANL	start-up output	-100 to 100	0	%

3.2.2 - Level 2 - Inputs

Input level allows to enable or disable (by means of the ANNUL option) the sensor type for input 1 and input 2. Sensor types include the linear options (0 to 5V, 0 to 10V, 0 to 55mV, 0 to 20A) and temperature (TEMP option) for input 1, and linear options only (0 to 5V, 0 to 10V, 0 to 20mA) for input 2, as illustrated in figure 15.

4 to 20mA input belongs to 20mA option
 1 to 5VDC input belongs to 5V option

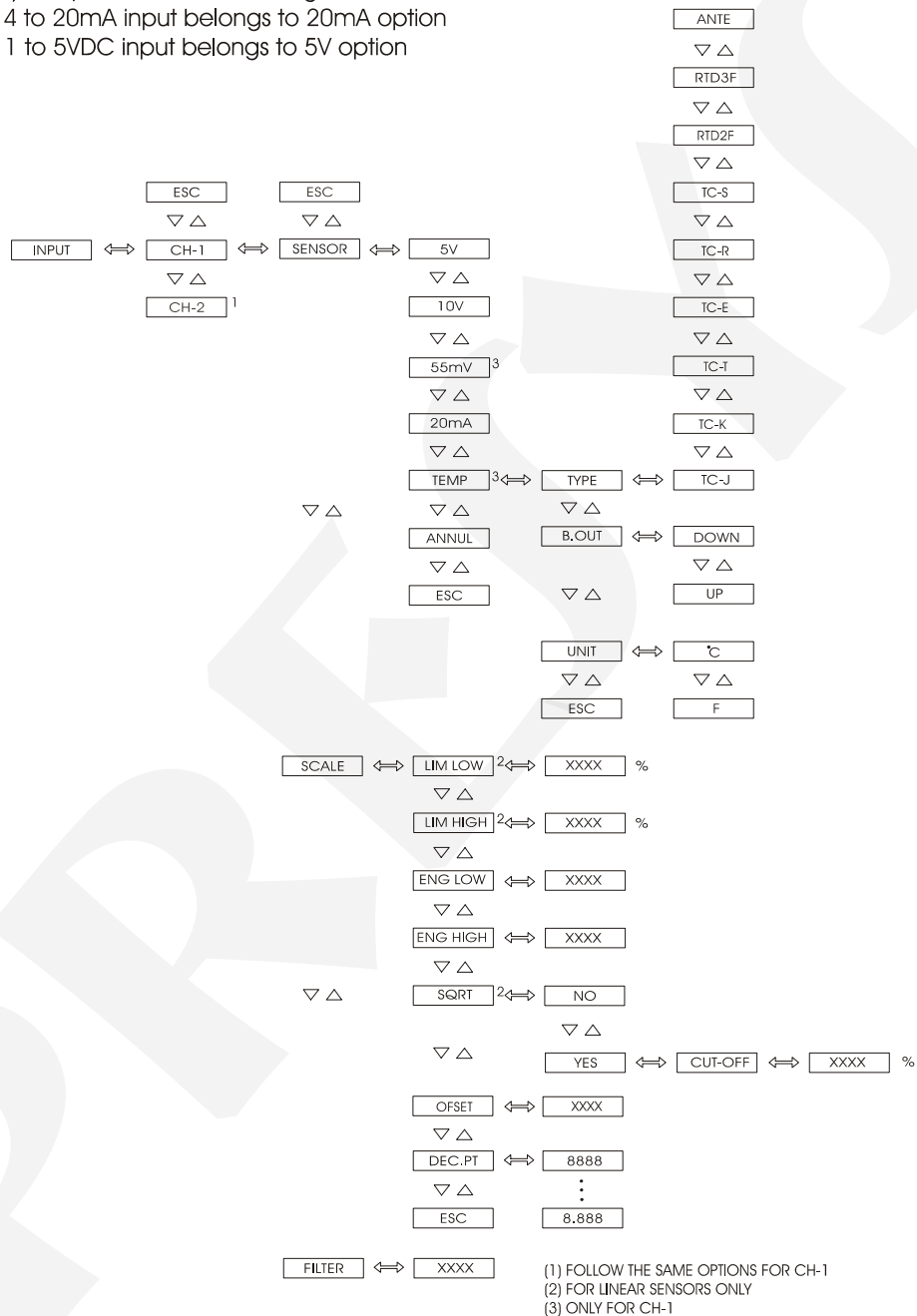

Fig. 15 - INPUT Level Options

The adjustable parameter ranges shown on figure 15 are given below.

Mnemonic	Parameter	Adjustable Range	Factory Value	Units
LIM LOW	input signal associated to Eng Low	0.0 to 100.0	0.0	%
LIM HIGH	input signal associated to Eng High	0.0 to 100.0	100.0	%
ENG LOW	display indication associated to Lim Low or lower limit for retransmission	-999 to 9999	0.0	EU*
ENG HIGH	display indication associated to Lim High or upper limit for retransmission	-999 to 9999	100.0	EU
CUT-OFF	minimum square root value	0 to 5	0	%
OFF SET	constant added to display indication	-999 to 9999	0	EU
FILTER	time constant of first order digital filter	0.0 to 25.0	0.0	seconds

(*) UE - Unidade de Engenharia

Whenever a linear sensor is selected, the scale should be configured (SCALE option); for that purpose, two points P1 (Lim Low, Eng Low) and P2 (Lim High, Eng High) must be defined, as illustrated on figure 16. Lim Low represents the value of the electrical signal, in %, associated to the display indication Eng Low, and Lim High corresponds to the value of the electrical signal, in %, associated to the display indication Eng High.

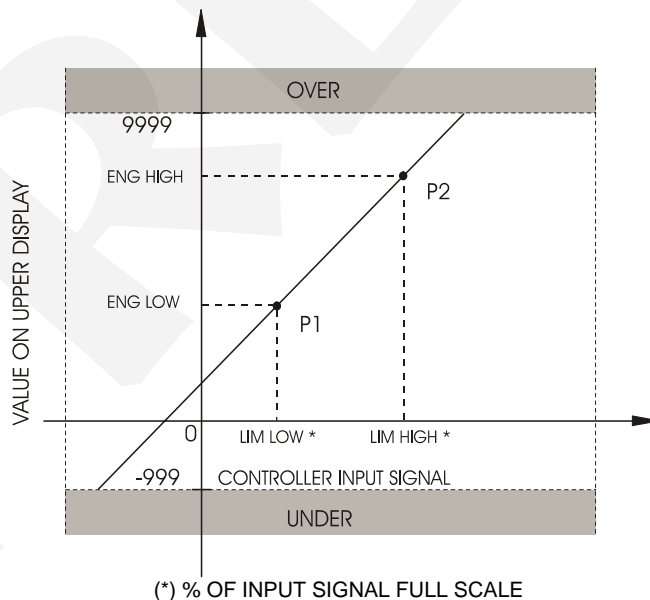

Fig. 16 - Linear Input Configuration

Eng Low and Eng High parameters also define the process variable indication range to be retransmitted by output 2 (when heating-cooling control mode is not used). The Eng High display indication corresponds to the output full scale (Lim High from output 2, for an analog output, or contact closed for 100% of PWM period, for a relay), and Eng Low indication, to zero scale (Lim Low from output 2, or contact closed for 0% of PWM period, that is, the contact remains opened). See sections 3.2.3 on Output and 3.2.5 on Control.

SQRT - allows presenting the square root of the controller input signal. The Cut-Off parameter, expressed as a % of the input signal full scale, makes the input values less than (Lim Low + Cut Off) to be shown as Lim Low. See illustration on figure 17.

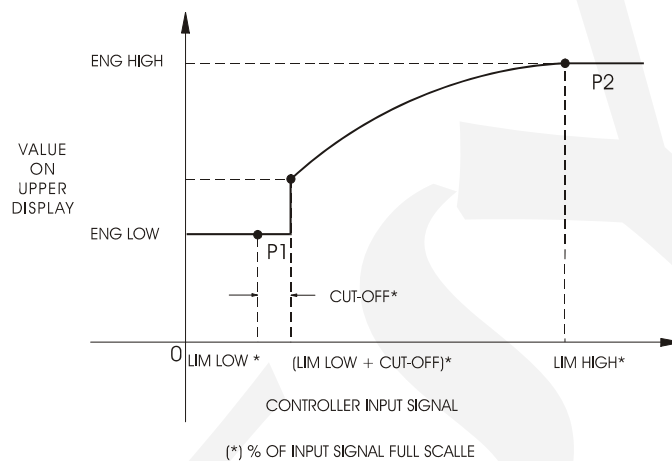

Fig. 17 - Square root of input signal

DEC.PT - sets the decimal point to exhibit the engineering units on the upper display. Up to three decimal places may be set for linear processes whereas temperature sensors may have one or no decimal place.

OF.ST - allows the user to enter a fixed off-set value, in engineering units, in addition to the value shown on the upper display.

FILTER - time constant for a first order digital filter associated with the selected input. Whenever no filtering of the controlled signal is desired, assign zero to this parameter.

B.OUT - in case of temperature sensor failure (thermocouple or RTD) or break of the connection wire to input 1, the display indicates burn-out. In such cases, the UP option for this parameter activates the high alarms and the DOWN option activates the low alarms. When occurring the burn-out with the controller in the automatic mode, it is automatically switched to the manual mode and the output changes to the value defined for PO.BR parameter. When occurring the burn-out with the controller in the manual mode, it remains in manual mode and the output continues with the value adjusted by the operator, not changing to PO.BR value. When the controllers leave the burn-out condition, they return to the mode in which they were operating prior to occurrence of burn-out.

UNITS - selects °C or °F for temperature indication.

NOTE: THE CONTROLLERS HAVE ALREADY COLD JUNCTION COMPENSATION FOR MEASUREMENTS WITH THERMOCOUPLE.

The software configuration of the inputs must be complemented by the hardware configuration of the process inputs, by means of internal jumpers. There are four places of jumper installation for input 1: J5, J6, J7 and J8; and also four places of jumper installation for input 2: J1, J2, J3 and J4.

They are located on the CPU Board. The table below shows the jumpers to be installed for each input type. Check the input type desired and place the jumpers as specified. Be sure that only the jumpers corresponding to the desired input are installed.

Input Types	Jumpers							
	Channel 1				Channel 2			
Thermocouple	J5		J7		Not applied			
Voltage (0 to 55mV)	J5		J7		Not applied			
Voltage (0 to 5V)	J5		J7		J1			J4
Voltage (0 to 10V)		J6					J3	
2-wire or 3-wire RTD	J5		J8		Not applied			
Current (0 to 20mA)		J6	J7				J3	J4

3.2.3 - Level 3 - Output

Level 3 allows the output types to be configured according to the optional module internally installed in the controllers (see figure 18). For control or retransmitting outputs 1 and 2 there are six types of output available: current (4 to 20mA), voltage (1 to 5V, 0 to 10V), SPST relay, open collector voltage and solid-state relay.

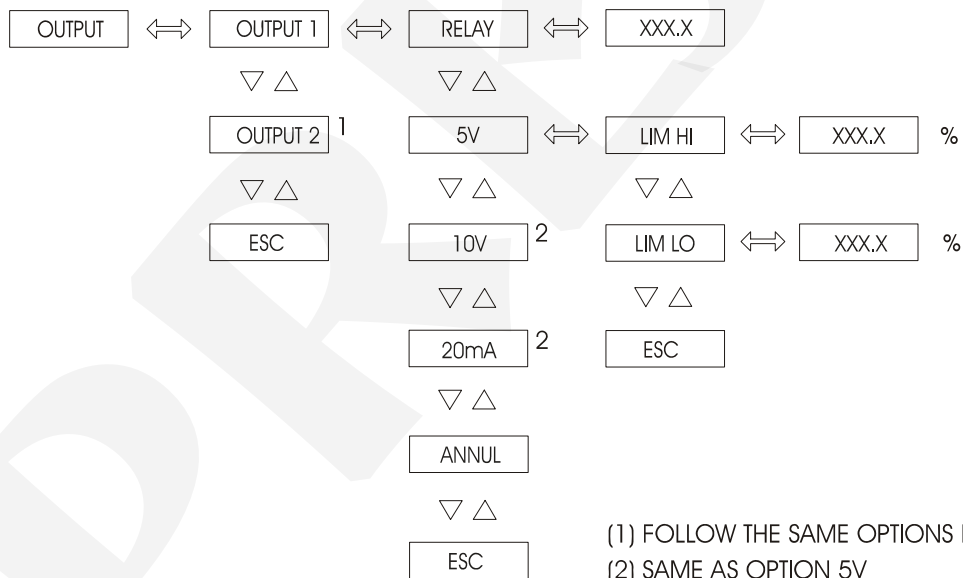

Fig. 18 - OUTPUT Level Options

Output 1 is used only as control output. Output 2 can be used as a retransmitter output, providing a linear signal corresponding to the process variable measured, or as an auxiliary output for heating-cooling control, operating together with output 1 (heating), when the heating-cooling control is configured.

The adjustable parameter ranges shown on figure 18 are given below.

Mnemonic	Parameter	Adjustable Range	Factory Value	Units
LIM LOW	Percentage of output full scale (20 mA, 5V or 10V) defining the lowest output signal. The output saturates in this value.	0.0 to 100.0	0.0	%
LIM HIGH	Percentage of output full scale (20 mA, 5V or 10V) defining the highest output signal. The output saturates in this value.	0.0 to 105.0%	100.0	%
RELAY	Time associated to relay cycle (PWM period). This represents the heating time for output 1 and cooling time for output 2.	1.0 to 120.0	10.0	s

The control output will only be enabled after the output type is selected with the values are assigned to the related parameters.

Whenever configured for current and voltage, outputs 1 and 2 must have their limits specified by the Lim Low and Lim High parameters. Note that Lim Low and Lim High are expressed as a percentage of output full scale and that the output signal saturates at those points. For example, in order to have a current output of 4 to 20mA, we should assign 20.0% for Lim Low and 100.0% for Lim High.

Whenever output 1 or 2 is configured as relay, the cycle period must be specified.

The optional module for output 1 must be plugged to the MOD1 connectors on the Power Supply Board, and output 2 to MOD2 connectors. To configure the analog output optional module for the output types 4 to 20mA, 1 to 5V or 0 to 10V, install the jumper as specified on the table below.

Analog type output	Jumpers on the analog output module	
4 to 20mA	Without jumper	
1 to 5V	J1	
0 to 10V		J2

3.2.4 - Level 4 - Alarms

In level 4, one configures alarm outputs 3 and 4, called relays 3 and 4, respectively (see figure 19). A maximum of two alarm relays may be available through the acquisition of the corresponding option modules. The possible output types for relays 3 and 4 are: SPDT relay, open collector voltage or solid-state relay.

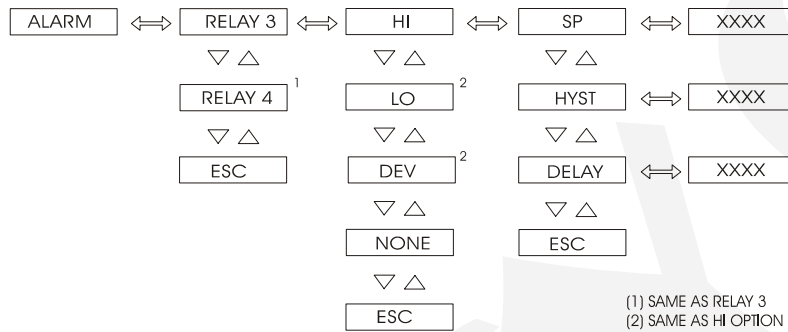

Fig. 19 - ALARM Level Options

There are three possible types of alarm: low, high and deviation. Each relay can be associated to the setpoint (SP) and the hysteresis (HYST) of only one type of alarm. For the deviation alarm, SP denotes the range above and below the local or remote setpoint which determine the lower and higher points where the deviation alarm occurs. The alarm relays are enabled only after the user has selected the setpoint values and pressed the ENTER key.

The adjustable parameter ranges shown on figure 19 are given below.

Mnemonic	Parameter	Adjustable Range	Factory Value	Units
SP	low or high alarm setpoint	-999 to 9999	75.0	EU
HYST	alarm hysteresis	0 to 250	10	EU
DELAY	delay for relay activation	0.0 to 999.9	0.0	seconds
SP	deviation alarm setpoint	1 to 9999	75.0	EU

DELAY - it causes the alarm operation of each relay to be delayed by a user defined period of time. Figure 20 below, illustrates the delay occurrence for a high alarm.

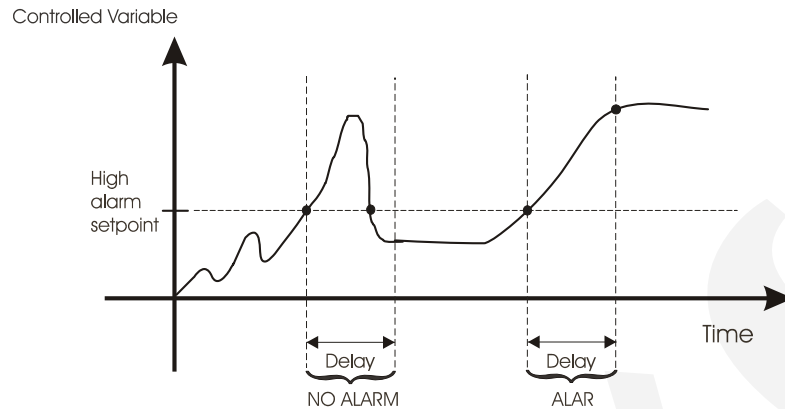

Fig. 20 - Relay with delay

The optional output module for output 3 (relay 3) must be connected to MOD3 connectors on the Power Supply Board, and for output 4 (relay 4) to MOD4.

Relay modules are provided with circuits for eliminating electrical arch (RC snubber). The snubbers are put in parallel with the relay contacts, by placing the jumpers J1 and J2 located on the back of the relay board. When the jumpers are not placed, the relay contacts are kept without snubbers. The relay module is sent from factory with the jumpers placed.

Note the position of the jumpers in the following figure.

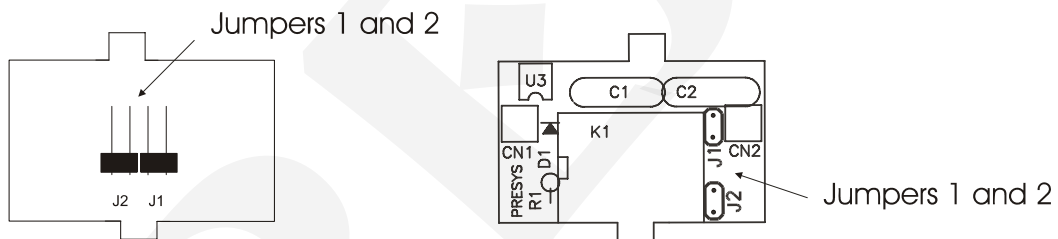

Fig. 21 - Jumpers for selection of snubbers on the relay board

Alarm and control relays are extremely critical in control and safety of industrial processes. In order to ensure the expected relay behavior, consider the following two loading conditions:

- High currents circulating through the relay contacts (from 20mA to 3A). When the relay switches high currents there is the occurrence of electrical arch which damage quickly the relay contacts. Besides, electrical noise is generated. In these conditions, it is recommended to use the RC snubbers which come with the relay module (placed jumpers).
- Low currents circulating through the relay contacts (less than 20mA). The relays could not function properly when the jumpers are placed. In this case, the snubbers maintain a 4.5mAac/9.0mAac current when connected to a 120VAC/220VAC circuit. This current is enough, in certain cases, to power a horn or alarm lamps, preventing their deactivation. In this situation, there is no need to use the snubbers and the jumpers must be removed.

3.2.5 - Level 5 - Control

In level 5, the control mode is selected for the DCY-2050/2051/2060 *Light* controllers. The control capabilities of the controllers include:

- PID Control with voltage or current output.
- PID Control with relay output (time proportioning).
- Dual Output Heating-Cooling Control.
- ON/OFF Control.

They can also be configured for:

- Ratio Control.
- Control with Remote Setpoint Input.
- Control with Programmable Setpoint (see section 3.2.7 on Programmable Setpoint).

Level 5 presents the options: SP.TP and CTR.M (see figure 22).

SP.TP - setpoint type used by the control block. The options for SP.TP are L.SP and RE.SP.

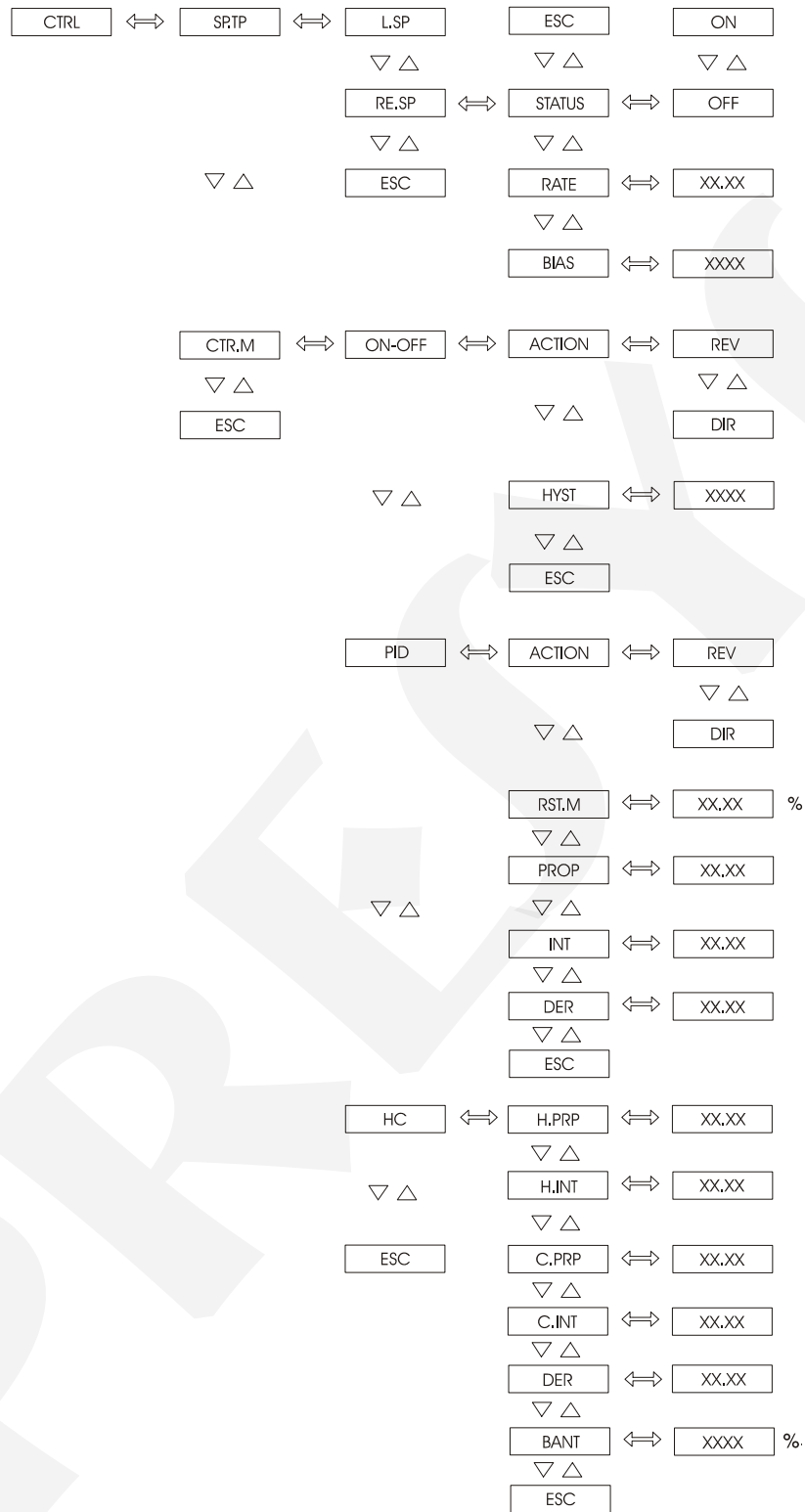

Fig. 22 - CONTROL Level Options

L.SP - this is the option for local setpoint, whose value is introduced manually by the user on the lower display through the UP and DOWN keys during the operation mode of the controllers.



Fig. 23 - Diagram of control blocks and display for local setpoint

RE.SP - this is the option for the remote setpoint input. This setpoint is introduced via the controller input 2.



Fig. 24 - Diagram of control blocks and display for remote setpoint

STATUS - this is the option which actually enables (RUN) or disables (OFF) the remote setpoint. It allows to switch quickly between the local setpoint and the remote setpoint.

When the remote setpoint is enabled, the UP and DOWN keys will not change the setpoint value shown on the lower display, since it is determined externally. Otherwise, the local setpoint is still enabled.

Input 2, which receives the remote setpoint signal, is adjusted to the span of input 1 given in engineering units by means of the RATE and BIAS parameters, according with the equation shown below:

$$RE.SP = RATE \times (Input\ 2) + BIAS$$

RATE, BIAS - gain and offset for adjusting the span of input 2, in engineering units, to the span, in engineering units, of input 1.

CTR.M - configuration of the control modes (ON/OFF, PID, Heating-Cooling) described below.

ON/OFF Control

ON/OFF - refers to the ON/OFF control mode.

ACTION - this option determines the direction of the control action (direct or reverse).

REV (reverse) - whenever REV is selected for control action (ACTION), the output signal is switched OFF when the controlled variable exceeds the setpoint value plus the hysteresis (upper limit) and switched ON when the variable falls below the setpoint minus the hysteresis (lower limit).

DIR (direct) - whenever DIR is selected for control action (ACTION), the output signal is switched ON when the controlled variable exceeds the setpoint value plus the hysteresis (upper limit) and switched OFF when the variable falls below the setpoint minus the hysteresis (lower limit). The ON/OFF control mode with reverse action is illustrated on figure 25 below.

HYST (hysteresis) - this is the range above or below the setpoint value which determines the lower and upper limits for switching the relay contacts.

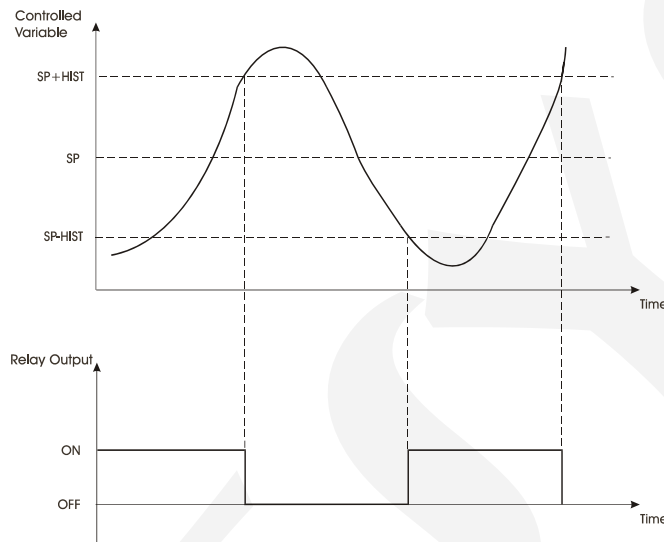

Fig. 25 - ON/OFF control with reverse action

PID control

PID - it associates the PID control mode to the control block.

ACTION - this option determines the direction of the control action (direct or reverse).

REV (reverse) - whenever REV is selected for control action (ACTION), an increase in the input signal will decrease the output signal. The error (E) between the setpoint (SP) and the controlled variable (Y) is defined in the reverse action as: $E = SP - Y$.

DIR (direct) - whenever DIR is selected for a control action (ACTION), an increase in the input signal will increase the output signal. The error (E) between the setpoint (SP) and the controlled variable (Y) is defined in the reverse action as: $E = Y - SP$.

The choice between direct and reverse action will depend on the system to be controlled.

In the PID control mode, the controller output (U) is related to the setpoint (SP) and to the controlled variable (Y) through the following equation described in continuous time:

$$U(t) = \frac{PROP}{ENGLISH - ENGLW} \cdot \left[E(t) + INT \int E(t)dt \pm DER \cdot \frac{d}{dt} Y(t) \right] + RSTN$$

In direct action, the positive sign before the derivative is adopted and the error (E(t)) is taken as the input (Y(t)) minus the setpoint (SP).

In reverse action, the negative sign before the derivative is adopted and the error (E(t)) is taken as setpoint (SP) minus the input (Y(t)).

The coefficients appearing in the above equation are selected within the PID option and have the following meaning:

PROP - it amplifies the error signal between the setpoint and the controlled variable to establish the output signal.

RSTM - this is the controller manual reset defined as an offset added to the controller output signal. It will always be required when proportional control mode (P) or proportional plus derivative control mode (P+D) is used, in order to eliminate the offset between the setpoint and the controlled variable.

INT - this is the integral ratio expressed in terms of repetitions per minute. It is defined as the number of times the integral action will repeat the proportional action resulting from the occurrence of a step in the controlled variable in 1 minute. The integral action or automatic reset is the most important parameter determining the setpoint control. While there is an error between setpoint and controlled variable, the integral action will actuate on the output signal until the error goes to zero.

DER - this is the derivative time given in minutes. It is defined as the time advance which the derivative action causes on the output signal in relation to the proportional action whenever a ramp occurs in the controlled variable. The derivative action provides a quick response at the control output resulting from any rapid variation in the controlled variable. It is used to eliminate oscillations. Note that in the DCY-2050/2051/2060 *Light* controllers the derivative is applied to the controlled variable: it inhibits the derivative action whenever only the setpoint is changed.

Time proportioning control

This PID control mode is provided with an ON/OFF output device: SPST relay, solid-state relay or open collector voltage connected to output 1. Note that in this control type, it is the ON time of the output device that varies according to PID output computation. The device ON/OFF period being constant and defined by the user at level 3 for output configuration (RELAY parameter), it is the duty cycle that actually varies.

The heating-cooling control mode also allows the use of ON/OFF modules for outputs 1 and 2.

Dual output control (heating-cooling)

HC - associates the heating-cooling control mode to the control block.

The heating-cooling control mode is obtained by dividing the scaled output from -100.0% to 100.0% into two parts: the cooling band (-100.0% to 0.0%) and the heating band (0.0% to 100.0%). The transition point between the two bands is 0.0%. Enabling of the heating or cooling output depends on the PID output computation relative to the transition point 0.0%. Whenever the computed output is above the transition point the heating output is enabled and when the computed output is below the transition point the cooling output is enabled. At each moment there is only one enabled output (see figure 26).

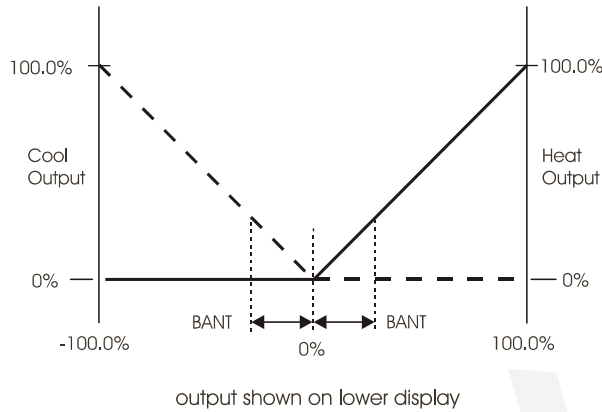

Fig. 26 - Heating-cooling output transition

In the heating-cooling control, the gain, integrative ratio and derivative time values may be changed when crossing from the cooling band to the heating band. Such changes should not happen in an abrupt way, as it would correspond to a violent change in control output. In order to prevent such effect, a transition band is defined (BANT) below and above the transition point where the PID parameters vary, as it is illustrated in figure 27.

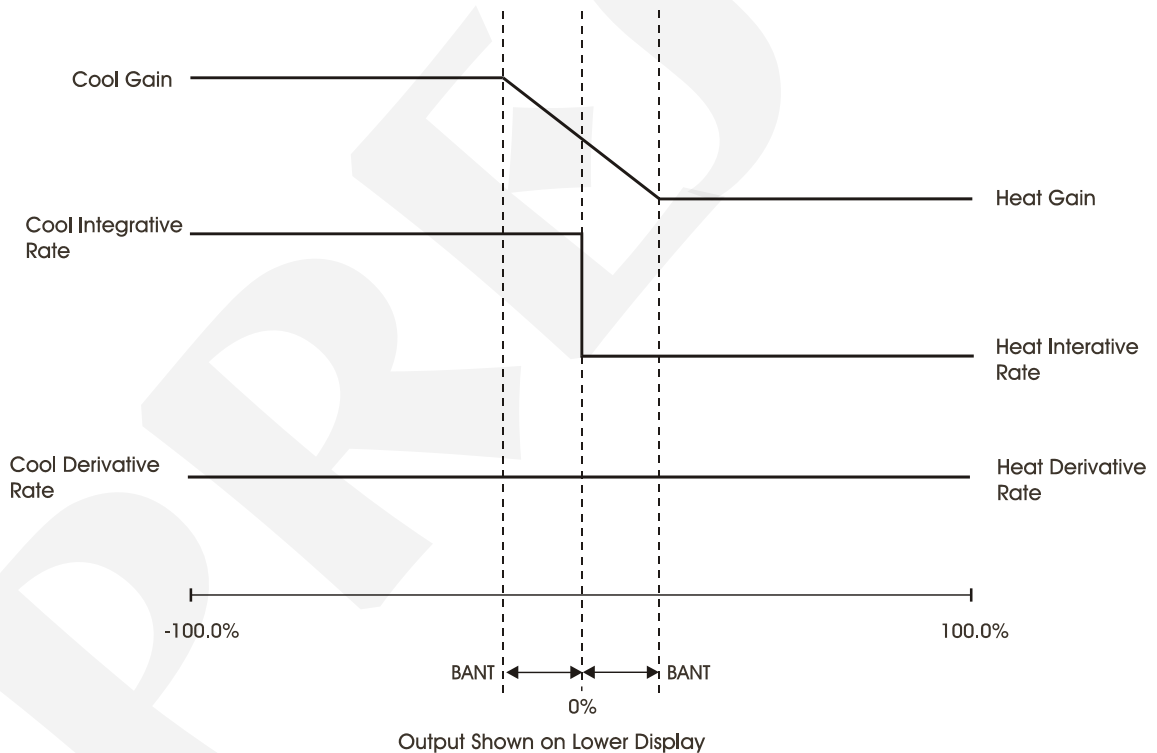

Fig. 27 - PID parameter variation in the heating-cooling transition

As it can be seen on the above figure, the gain in the transition zone shows a linear variation, the integrative ratio shows a step in its variation at that point and the derivative time remains the same. Those parameters correspond to the following mnemonics:

- BANT - transition band defined above and below the transition point
- H.PRP - PID gain for the heating output
- H.INT - PID integrative ratio for the heating output
- C.PRP - PID gain for the cooling output
- C.INT - PID integrative ratio for the cooling output
- DER - PID derivative time common to heating and cooling outputs

Whenever the heating-cooling control is selected, output 1 will be the heating and output 2 will be the cooling output. For outputs 1 and 2, one may have the following internally optional module types: voltage output, current output, SPST relay, solid-state relay and open collector voltage.

The adjustable parameter ranges shown on figure 22 are given below.

Mnemonic	Parameter	Adjustable range	Factory Value	Units
RATE	Rate	0.01 to 99.99	1.00	-----
BIAS	Offset	-999 to 9999	0	EU
HYST	Hysteresis	-999 to 9999	0	EU
PROP	Proportional Gain	0.01 to 99.99	1.00	-----
RSTM	Manual reset	0 to 99.99	50.0.	%
INT	Integrative rate	0 to 99.99	0.00	rep/min
DER	Derivative time	0 to 99.99	0.00	min
H.PRP	Heating gain	0.01 to 99.99	1.00	-----
H.INT	Heating integrative rate	0 to 99.99	0.00	rep/min
C.PRP	Cooling gain	0.01 to 99.99	1.00	-----
C.INT	Cooling integrative rate	0 to 99.99	0.00	rep/min
DER	Derivative time	0 to 99.99	0.00	min
BANT	Transition band	0 to 50	0	%

3.2.6 - Level 6 - Tune

The PID parameters of the DCY-2050/2051/2060 *Light* controllers, Proportional Gain (PROP), Integrative Rate (INT) and Derivative Time (DER) are adjustable over a wide range of values in order to be adapted to several processes with different characteristics. For a specific control application, these parameters should be adjusted in order to achieve the best system performance.

For this purpose, the DCY-2050/2051/2060 *Light* controllers are provided with auto-tune algorithms which, whenever activated by the user, will automatically compute, both on start-up (when the controlled variable is far from the setpoint) and on demand (the controlled variable is close to the setpoint), the optimum PID values based on the process reaction curve during the auto-tune cycle. After carrying out PID computation via the auto-tune algorithm the controllers start controlling the process in the automatic mode with those new values.

The auto-tune algorithm is only carried out provided:

- i) the setpoint is local.
- ii) the selected control algorithm is PID.
- iii) the programmable setpoint is not enabled: STATE parameter is OFF.

Warning:

Whenever the derivative time (DER) is configured as zero, the auto-tune algorithm will compute the parameters only for a PI control.

Before carrying out the auto-tune, the user should select the proper control action (reverse or direct) to meet the requirements of this process.

The auto-tune algorithm is not carried out in the ON/OFF control and in the heating-cooling control. For PID adjustment in the heating-cooling control the user should carry out the PID manual adjustment sequence described at the end of this section.

The auto-tune algorithm is carried out regardless of whether the controllers are in the automatic or manual mode.

Auto-tune on start-up

The auto-tune procedure on start-up is carried out whenever the controlled variable is far from its setpoint value, as is usually the case on start-up.

To enable the auto-tune on start-up, carry out the following steps:

- i) Enter the configuration level 6.
- ii) Select the ON option for the ST.UP parameter (auto-tune on start-up) and press ENTER.
- iii) Note that the controller goes to the normal operation mode and the TUNE message blinks on the upper display, indicating the auto-tune algorithm in running. When the auto-tune algorithm is finished, the TUNE message disappears from the upper display.

Auto-tune on demand

The on demand auto-tune procedure is carried out whenever the controlled variable is close to its setpoint value and the system has already achieved its steady condition. Therefore, before activating the auto-tune on demand make sure both the controlled variable and the control output are stable.

Whenever the auto-tune on demand is running, the controller generates a square wave in the control output with amplitude selected by the user (D.Out), centered on the output value, in order to cause oscillations on the controlled process, as illustrated on figure 28. Based on such oscillations, the auto-tune algorithm computes the PID parameters and the plant is controlled by those new parameter values.

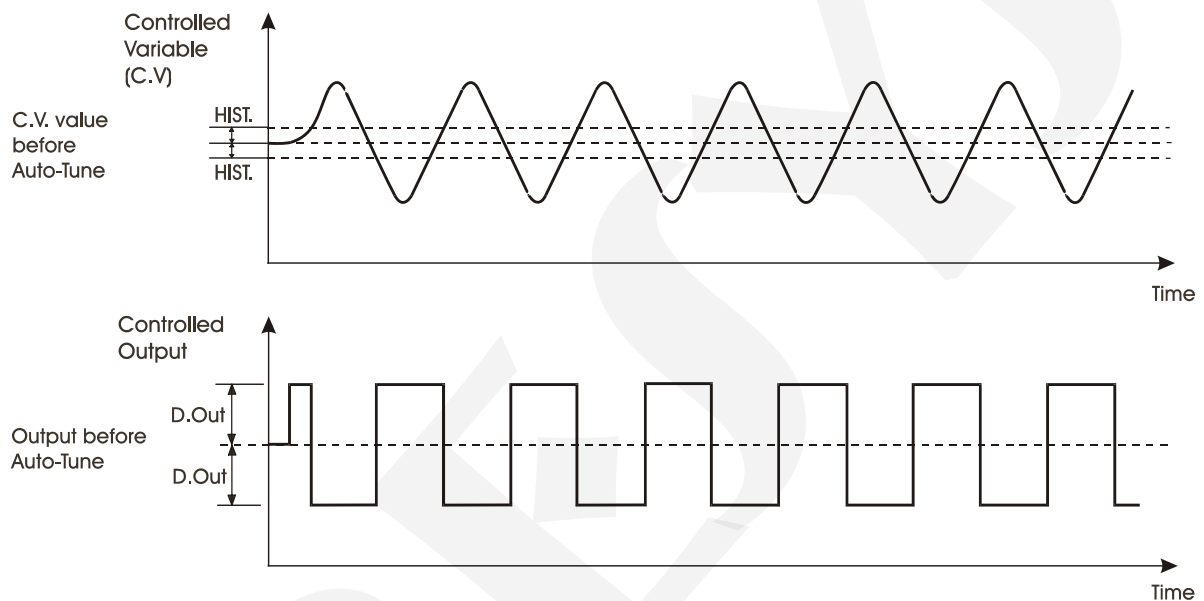

Fig. 28 - Process variable and control output for on demand auto-tune

D.Out - determines the amplitude of the square wave generated in the control output for auto-tune computation. The control output will vary this value up and down from its present output.

Hyst - determines when the output should be changed. Whenever the control variable crosses the upper and lower hysteresis limits, the controller output should cause the output value to vary D.Out value for more or for less from its original value.

LIM.S, LIM.I - correspond to the upper and lower safety limits (trip point), which determine a range within which the control variable can vary due to the auto-tune process. In case the control variable goes out of this range the auto-tune process is aborted.

To enable the on demand auto-tune follow the steps:

- i) Enter the configuration level 6.
- ii) Select the amplitude of the square wave (D.Out) and the hysteresis (Hyst). See figure 28.
- iii) Select the ON option for the AUTO parameter (auto-tune on demand) and press ENTER.

Note that as soon as the third step is completed the controllers will go to normal operation mode with the TUNE message and the controlled variable alternating on the upper display. Upon completion of the auto-tune cycle the instrument no longer displays the TUNE message (see figure 29).

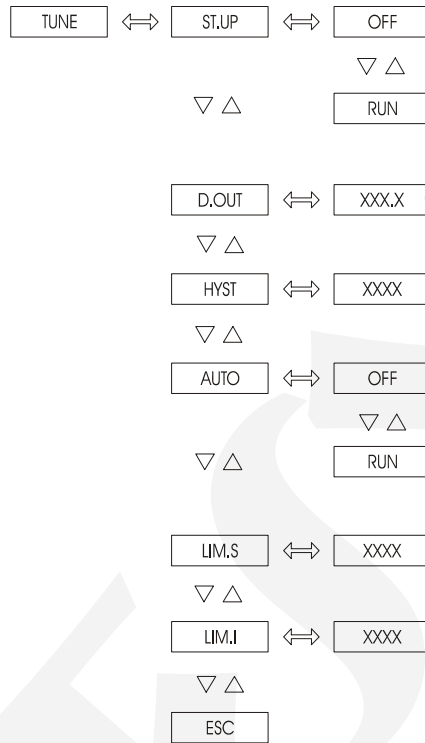

Fig. 29 - TUNE Level Options

The adjustable parameter ranges shown on figure 29 are given below.

Mnemonic	Parameter	Adjustable Range	Factory Value	Units
D.Out	square wave amplitude	0 to 100.0	10.0	%
Hyst	hysteresis above and below the process variable	-999 to 9999	10	EU
LIM.S	Upper Limit	-999 to 9999	9999	EU
LIM.I	Lower Limit	-999 to 9999	-999	EU

PID manual adjustment

The manual adjustment of the PID parameters will be based on the Method of ultimate sensitivity developed by Ziegler and Nichols. By this method, the optimum PID adjustment will be that in which the process reaction curve shows consecutive oscillations peaks with amplitudes at the rate of 1/4.

In order to apply this method, the following described steps should be carried out:

- i) Set the integrative rate (INT) and the derivative time (DER) to zero, i.e., leave the controllers under proportional action only.
- ii) Set an arbitrary gain value (PROP) and record the controlled variable.
- iii) Adjust the gain value (PROP), also called sensitivity, until reaching a limit value in which the controlled variable will show a uniform oscillation, i.e., with constant amplitudes (see figure 30). Values above that limit produce amplifying oscillations, whereas gain values below that limit will dampen those oscillations. By ultimate sensitivity (K_u) it is meant that limit gain and by ultimate period (P_u) it is meant the period of constant oscillation caused by this sensitivity.

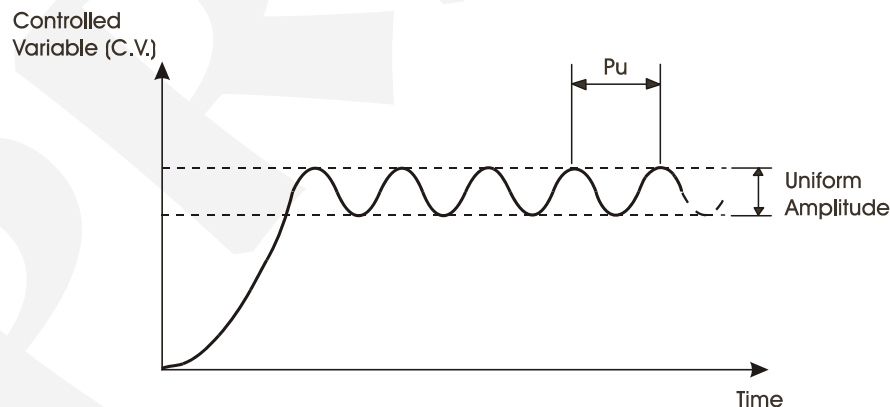

Fig. 30 - Steady state oscillation

Compute the optimum PID parameter adjustment according to the table below:

Control action	Gain	Integrative Rate (INT)	Derivative time (DER)
P	0.5 Ku	-	-
P + I	0.45 Ku	1/(0.83 Pu*)	-
P + D	0.6 Ku	-	0.125 Pu
P + I + D	0.6 Ku	1/(0.5 Pu)	0.125 Pu

Pu - given in minutes

*

PID Adjustment under the heating-cooling mode

Select the heating-cooling control mode (HC) in level 5. Assign to the derivative time (DER) the value obtained from the table. Set the heating integrative rate value (H.Int) to the same value of the cooling integrative rate (S.Int), both equal to the value obtained from the table. The heating gain may be obtained from the above table, but the cooling gain should be manually adjusted until the best system performance is achieved.

3.2.7 - Level 7 - SetP (Programmable Setpoint)

The DCY-2050/2051/2060 *Light* controllers can run a program which generates, repeatedly, up to ten setpoint values.

The setpoint values, the time taken to reach these values and the number of times this setpoint sequence should be repeated are parameters selected by the user within Configuration level 7.

Figure 31 shows an illustration of a wave form obtained from the setpoints programmed by the user. Note that the first setpoint (SP-1) is reached from the local setpoint and that after running the programmable setpoint the value to be used for the local setpoint will be the last value obtained by the programmable setpoint.

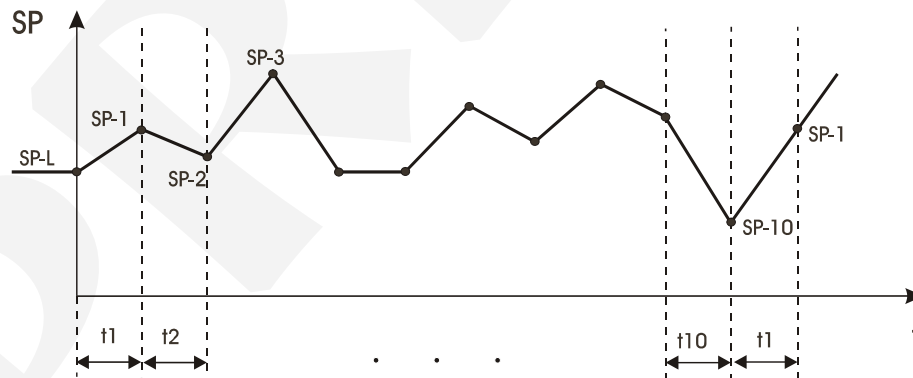

Fig. 31 - Evolution of the programmable setpoint

The adjustable parameter ranges are shown below.

Mnemonic	Parameter	Adjustable Range	Factor y Value	Units
L.C.	counter determining how many setpoint cycles will be performed or how many cycles are left before the end of the programmable setpoint execution.	1 to 250	1	repetitions
SP-1, SP-2, ... SP-10	setpoint value	-999 to 9999	5000	EU
t1, t2, ... t10	time to reach the setpoint	0 to 9999	0	minutes

When it is required less than ten setpoints in a cycle, set the time to reach the next setpoint value to zero. For example, if only two programmable setpoint values SP-1 and SP-2 are required, t3 should be set to zero.

Setpoint evolution will be shown on the lower display when the user returns to the operation level mode. In order to check how many cycles still remain before ending the program, the user should return to the programmable setpoint level 7 and see the value of parameter L.C.

3.2.8 - Level 8 - Calibration

WARNING: only enter the following options after completely understand them. Otherwise it might be necessary to send the instrument back to factory for recalibration. Calibration in this manual means adjustment.

The DCY-2050/2051/2060 *Light* controllers are accurately calibrated in factory and do not need periodic calibration in normal conditions. When calibration is required, follow this procedure below.

- Disconnect the process signals from I/O terminals.
- Before calibrating the instrument, keep it turned on for at least 30 minutes for warm up.

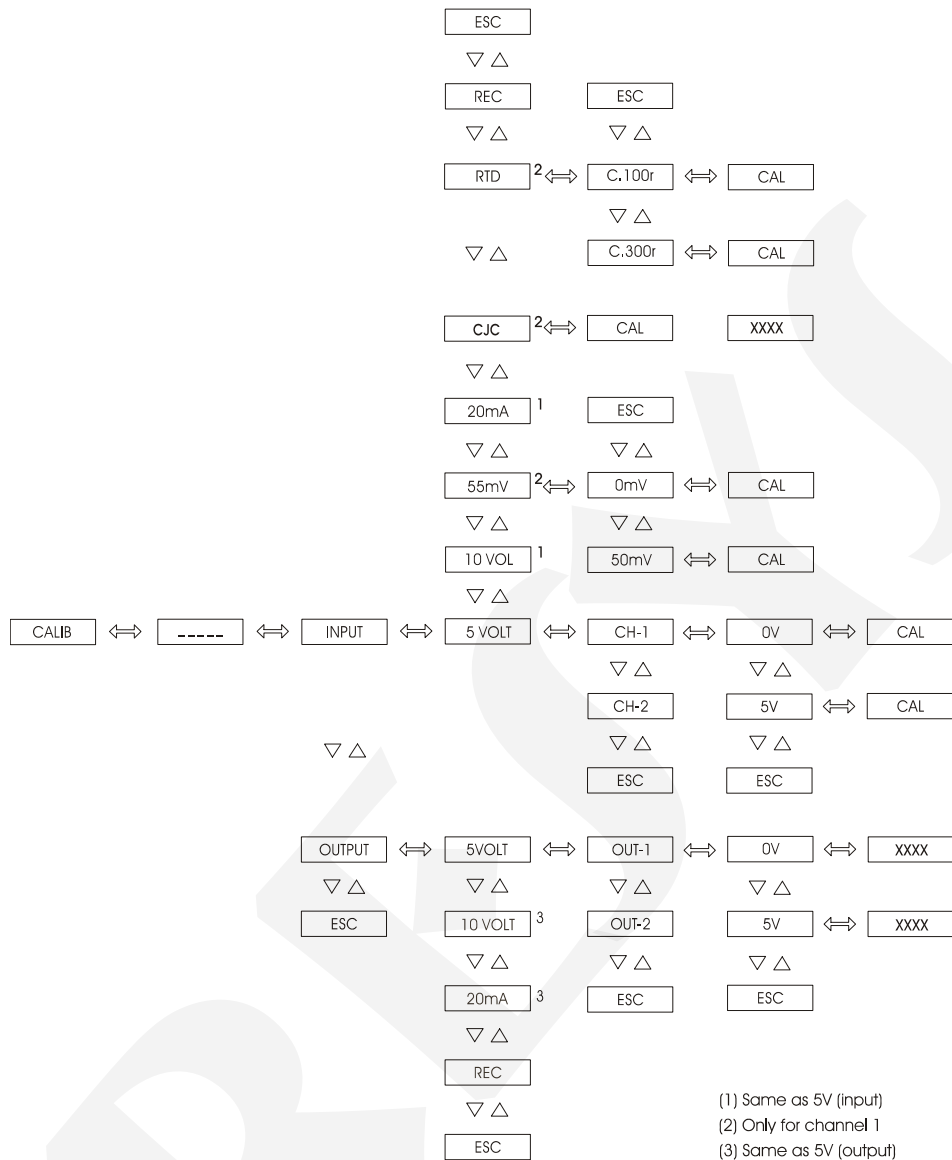

Fig. 33 - Calibration Level Options

Input calibration

Enter level 8 of Calibration and provide the password. **The password for entering this level is number 5.**

Select the input type to be calibrated. The display shows the mnemonics related to the references required for the calibration process. Apply the reference corresponding to the mnemonic shown on the display (see the Connection Diagram) and press ENTER. The controller begins the calibration process and the mnemonic CAL blinks on the display. The reference must be connect to the input until the display stops blinking and presents the mnemonic corresponding to the reference.

Change to the next reference and press DOWN to select another point. Wait at least 1 minute and press ENTER to start calibrating.

In order to return to normal operation move back through the hierarchical levels until reaching level zero.

Voltage (5V, 55mV and 10V) or current (20mA) input calibration

Connect an accurate DC voltage or current source to the proper input terminals (see Connection Diagram) and apply the two references of voltage or current required by the controller in the calibration level.

Calibration of thermocouple input

The thermocouple calibration of input 1 is performed in two steps. First perform 0 to 55mV and 1 to 5V calibrations of input 1. Once the voltage calibrations are done, access the CJC mnemonic in level 5 to start the automatic calculation of the cold junction temperature. Meanwhile the CAL mnemonic blinks on the display. After a few seconds, the display presents the temperature value given in °C. This value is a first approximation. Then, the user must measure the temperature of the I/O terminals and correct the value presented.

Calibration of 3-wire RTD input

In the 3-wire RTD calibration of input 1 use precision resistances of 100 and 300 ohms when required by the controller.

Output calibration

The analog outputs will be calibrated by the controller itself.

Be sure the internal jumper configuration of the Optional Analog Output Module corresponds to the output type configured by software (without jumpers for 20mA output, jumper 1 for 5V and jumper 2 for 10V) and connect the output terminals to the input terminals corresponding to the type of output to be calibrated (see the Connection Diagram).

Enter Calibration level 8 and select output 1 or 2, the output type (0 to 20mA, 0 to 5V or 0 to 10V) and press ENTER.

The display will show the mnemonic corresponding to the first calibration point. There are two output calibration points. When pressing ENTER after the selection of the calibration point, the display shows the output value. Use the UP and DOWN keys to adjust the output value to the electrical level indicated by the mnemonics. Press ENTER after adjusting. When calibrating the first point (0mA, 0V) care should be taken to avoid output signal saturation.

Return to normal operating level by moving back to level zero.

Returning to factory calibration

Enter calibration level 8, select the REC option and press ENTER to recover the factory calibration values.

3.2.9 - Level 9 - RS

Refer to the communication manual.

PRESYS

PRESYS

PRESYS INSTRUMENTOS E SISTEMAS LTDA.
RUA LUIZ DA COSTA RAMOS, 260 - SAUDE SAO PAULO SP BRAZIL
04157-020 - PHONE +55 (11) 5073.1900 - FAX +55 (11) 5073.3366

