

PRESYS

Instruments

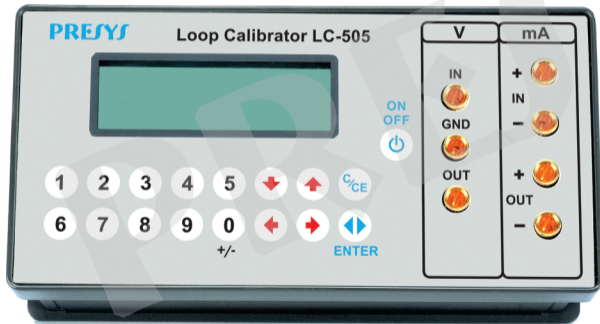

**LC-505
Loop
Calibrator**

TECHNICAL MANUAL

IMPORTANT INSTRUCTIONS:

- Keep LC-505 calibrator in a dry environment whenever possible. It can be put in a burn-in up to 50°C when it is a long time out of use.
- The fuse which protects the current measurement circuit, code 01.02.0277-21, is a special part. So, only replace the fuse by another original from factory.
- In case of failure, always send the instrument to the factory for repair.
- When not in daily use, before starting up, let the calibrator be turned on for at least one hour.

The warranty conditions are available in our sites:
www.presys.com.br/warranty

Table of Contents

| | |
|--|----------|
| 1 - Introduction | 1 |
| 1.1. General Description..... | 1 |
| 1.2. Specifications - Inputs | 3 |
| 1.3. Specifications - Output | 3 |
| 2 - Operation | 7 |
| 2.1. Parts Identification..... | 7 |
| 2.2. Battery and charger..... | 10 |
| 2.3. Using LC-505, basic functions..... | 11 |
| 2.4. Measurement or Input Functions..... | 16 |
| 2.5. Generation or Output Functions..... | 18 |
| 2.6. Available Power Supply (TPS) | 20 |
| 2.7. Application Examples | 21 |
| 2.8. Special Programming | 27 |
| 2.8.1. FILTER Programming | 28 |

| | |
|--|-----------|
| 2.8.2. DECIMAL Programming | 28 |
| 2.8.3. STEP Programming | 29 |
| 2.8.4. RAMP Programming | 31 |
| 2.9. Special Functions | 32 |
| 2.9.1. SCALE Function..... | 33 |
| 2.9.2. CAL Function..... | 35 |
| 2.9.3. SCALE Function..... | 38 |
| 2.9.4. CONV Function | 40 |
| 2.10. MEM Command | 42 |
| 2.11. LC-505 Warning Messages..... | 44 |
| 3 - Calibration and Maintenance | 45 |
| 3.1. Input Calibration | 47 |
| 3.2. Output Calibration | 48 |
| 3.3. Replacement of Current Input Fuse | 50 |

1 - Introduction

1.1. General Description

LC-505 calibrator enables measurement and generation of signals used in DC current (4 20mA) and voltage (1-5V, 0-10V) loops. Distinguished from regular loop calibrators due to its high-accuracy, possibility of simultaneous measurement and generation of isolated signals, real time connection with computer, working as a data acquisition point and full computer-aid for instrument calibration and adjustment tasks.

Its accuracy refers to changes in room temperature and maintenance of specifications for a long time of use. Designed for field use, it contains useful items as carrying case holders with fastener rings or belts for a hands-free operation. It includes rechargeable battery, and a high size memory intended to store values obtained for a later upload to a computer, when applicable. Moreover, various other constructive features aggregate quality and efficiency to LC-505, allowing also its field and workbench use.

Incorporates the most modern concepts of calibration and adjustment via computer, where data are shared between instrument and computer, improving efficiency in handling information through report and certificate issues, automatic work management, data organization and storage, for an overall coverage of quality procedure requirements, especially those related to ISO 9000.

When connected to a computer it can be used for real-time data acquisition.

1.2. Specifications - Inputs

| Input Ranges | | Resolution | Accuracy | Remarks |
|--------------|--------------------------|--------------------|------------------------------------|--|
| volt | -10 to 11V 11 to 45 V | 0.0001V 0.0001V | $\pm 0.02\%$ FS $\pm 0.02\%$ FS | $R_{\text{input}} > 1 \text{ M}\Omega$ |
| mA | -5 to 24.5 mA | 0.0001mA | $\pm 0.02\%$ FS | $R_{\text{input}} < 160 \Omega$ |

1.3. Specifications - Output

| Output Ranges | | Resolution | Accuracy | Remarks |
|---------------------------------|---------------|------------|-----------------|---------------------------------|
| volt | -1 to 11V | 0.0001V | $\pm 0.02\%$ FS | $R_{\text{output}} > 0.3\Omega$ |
| mA | 0 to 22 mA | 0.0001mA | $\pm 0.02\%$ FS | $R_{\text{max}} = 700\Omega$ |
| 2-wire Transmitter (XTR) | 4 mA to 22 mA | 0.0001mA | $\pm 0.02\%$ FS | $V_{\text{max}} = 60V$ |

Accuracy values are valid within one year and ambient temperature range from 20 to 26°C. Outside these limits add 0.001 % FS / °C, taking 23 °C as the reference temperature.

Special Software Functions

- Any output programmable in:

- 1) STEP:** 10%, 20%, 25% or up to 11 programmable set-points via key or adjustable time.
- 2) RAMP:** up and down with programmable travel and dwell time.

- Special Functions:

- 1) SCALE:** makes the scaling of both input and output in 6 digits with signal and allows the configuration of decimal point.
- 2) CAL:** scales the input in the same unit of output.
- 3) CONV:** converts any input into any output.

- Mem Command:

It can store up to 8 types of configuration chosen by the user.

Transmitter power supply: 23 Vdc, 30 mA, regulated.

Warm-up time: 5 minutes.

Operating temperature range: 0 to 50 °C.

Relative humidity: 90% RH non-condensing.

Battery operation:

- Up to 8 hours when generating mA (20 mA) or using 2-wire power supply; Up to 36 using only inputs.

Serial communication: RS-232 / RS-485.

Includes technical manual, test leads, carrying case and battery charger.
Calibration Certificate (Optional).

Dimensions: 56 mm x 144 mm x 72 mm (HxWxD).

Weight: 0.6 kg approx.

Note: Changes can be introduced in the instrument, altering specifications in this manual.

2 - Operation

2.1. Parts Identification

a - Front Panel

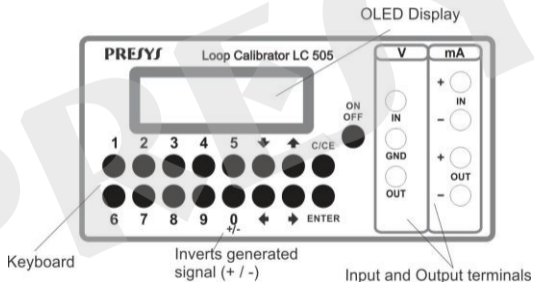
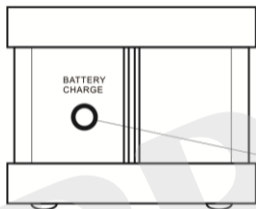
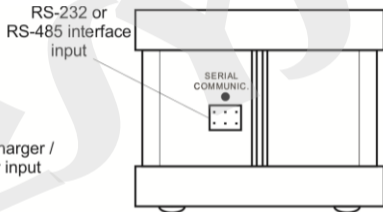
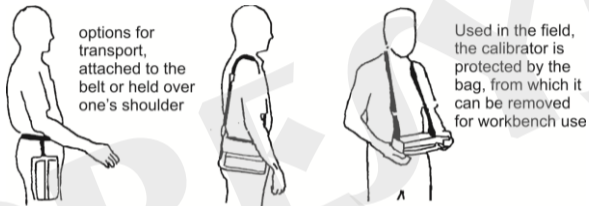

Figure 01 - Front Panel

b – Left side-view panel**c – Right side-view panel**

Battery charger /
adaptor input

Figure 02 - Side Panels

d - Carrying case, way of use**Figure 03** - Ways to use the carrying bag

e - Accessories: The carrying case has two compartments, one is used to house the calibrator and the other is used to keep several accessories such as test leads, spare fuse, straps for transport and use in field, and also the technical manual.

f - Optional Items: RS-232 / RS-485 interface and ISOPLAN calibration software. The optional items are described in specific manuals.

2.2. Battery and charger

LC-505 is supplied with rechargeable battery which enables up to 36 hours of continuous use, or less, mainly when the 4-20 mA output or the 23 Vdc power supply for transmitters is used. A charger is provided, which can be connected to 100 240 Vac. The time required for a full charge is 14 hours. When the display indicates LOW BAT, it is necessary to recharge the instrument, which will continue in operation for a few minutes. The charger provides the battery charge while it feeds the calibrator, thus allowing the calibrator to be used while the battery is being charged.

The batteries used by the LC-505 are Nickel-Metal Hydride (Ni-MH).

2.3. Using LC-505, basic functions

When the calibrator is powered on, the display shows:

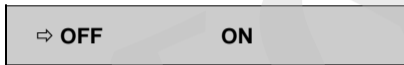

If the user does not select **ON** and press ENTER within 12s, the instrument will turn off itself. Its purpose is to save battery from turning the instrument on accidentally while in the carrying case.

When **ON** is confirmed, the calibrator goes through a self-test routine and shows the last calibration date and the value of the battery voltage; in case of failure, it displays a message to indicate RAM error or E2PROM error; if that occurs, contact Presys Technical Assistance. The battery voltage is constantly monitored and the low battery warning is provided. After the self-test, the display shows the starting menu:

| | | |
|----------------------------|--------------------------|---------------------------|
| ⇒ IN CONF | OUT CAL | EXEC COM |
|----------------------------|--------------------------|---------------------------|

IN / OUT - selects the input/output functions.

CAL - selects adjustment functions of the calibrator (see section 3 - Calibration).
Do not enter in CAL option before reading the warning in section 3.

COM - refers to the communication with the computer, described in an appropriate manual.

EXEC - used to activate an input or output option which has been previously selected.

CONF - takes to the sub-menu:

| | | | |
|-------|-----|------|----|
| ⇒ OFF | MEM | PRG | FN |
| BAT | DSP | DATE | |





OFF - LC-505 incorporates energy saving resources (battery) through the automatic power off option (auto-OFF). This option has the following sub-menu:

| | |
|-------|-------|
| ⇒ NO | 5MIN |
| 15MIN | 30MIN |

When **NO** is selected, the energy saving option is disabled.

In case 5, 15 or 30 min is selected, LC-505 will turn off automatically after this period if the keyboard is not used.

DATE - updates the date and time for LC-505. Thus, when LC-505 performs a calibration within the COMMUNICATION option, calibration data is recorded together with their date and time of occurrence.

Whenever LC-505 is turned off, the date and time are not updated any longer. Thus, if you want them to be recorded with the calibration, you should update them. For such, use the vertical arrow keys  and  to change the value which is blinking and the horizontal arrow keys  and  to go to another value. The ENTER key confirms the last selection.

BAT - shows the value of the battery voltage since the battery charger/adaptor is disconnected. When connected, **BAT** shows the DC level which is provided by LC-505 charger/adaptor.

| Battery Level | Battery State | Display |
|---------------|---------------|---------|
| 4.0 to 7.0V | normal | ----- |
| <4.0 V | low | LOW BAT |

DSP - performs the setting of the display contrast by means of the arrow keys **▲** and **▼** the last selection is saved by pressing the ENTER key.

PRG, FN, MEM are resources of LC-505 described further on.

2.4. Measurement or Input Functions

Select the type of signal to be measured by using the menus and use the corresponding terminals:

- a) **IN** – Selects the input function.



Press **ENTER** to select V (volt) measurement; press **↓**, **↑**, **←** and **→** to select another signal.

IN = x.xxx V
C/CE
NO

Display indicates volt input with large digits.
Returns to the previous menu.
Disables the input function.

The mA input follows the same selection process.

b) Input or Measurement Connections

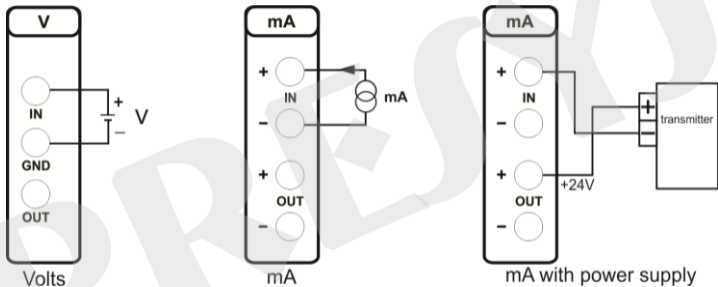



**Figure 04 - Input Connections**

2.5. Generation or Output Functions

Select through the menus the type of signal to be generated and use the corresponding terminals:

- a) **OUT** – Selects the output functions.



Press ENTER to select V (volt) source; press , ,  and  to select another signal.

- OUT = x.xxxx V** Display indicates the value of the output in volts with large digits. The sign can be inverted with the key 0 (+/-).
- C/CE** Returns to the previous menu.
- NO** Disables the output function.

The mA output follows the same selection process.

b) Output or Generation Connections

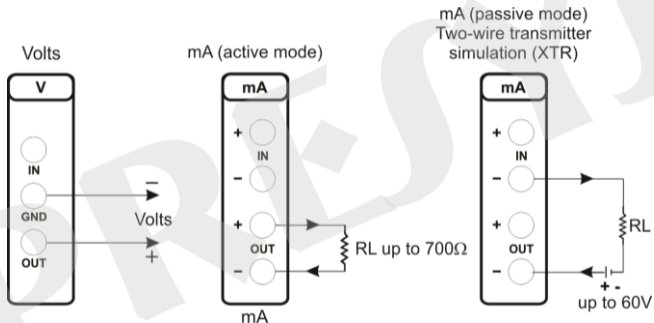
**Figure 05** - Output or Generation Connections

2.6. Available Power Supply (TPS)

LC-505 has a +23 Vdc regulated power supply (TPS), with short-circuit protection (current limited to 30 mA).

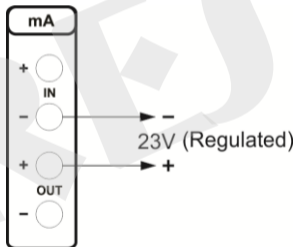

Figure 06 - Available Power Supply (TPS)

2.7. Application Examples

Despite its capability of showing simultaneously input and output functions in the display, there is no isolation between each other. This means that when LC-505 is connected to a converter (I / V, V / I, I / I or V / V) it may not function appropriately or damage the set, in case the converter is not galvanically isolated. Thus, when using LC-505 input and output connected to a converter, it is important to make sure the converter is isolated (independent grounds).

a) Calibration of four-wire transmitters

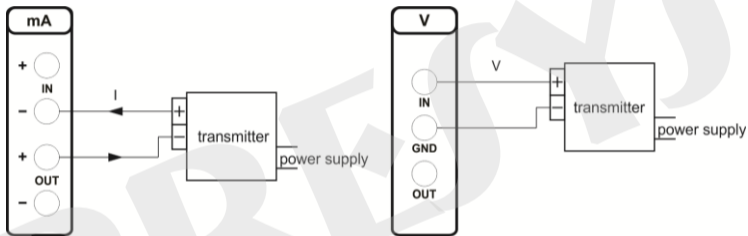
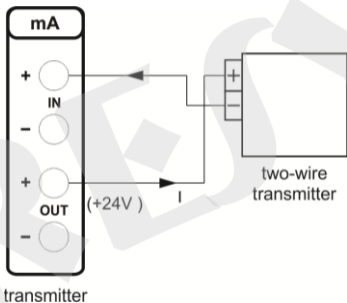

Figure 07 - Four-wire transmitter calibration

b) Calibration of two-wire transmitter

**Figure 08** - Two-wire transmitter calibration

c) Current Supply

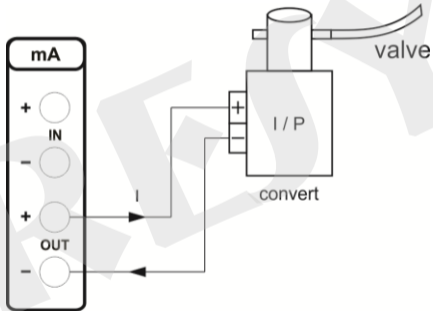
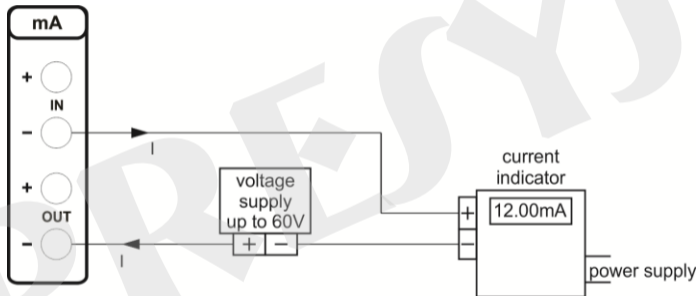

Figure 09 - Current Source

d) Two-wire transmitter simulation (XTR)

**Figure 10** - Two-wire transmitter simulation (XTR)

e) I / V Converter (isolated)

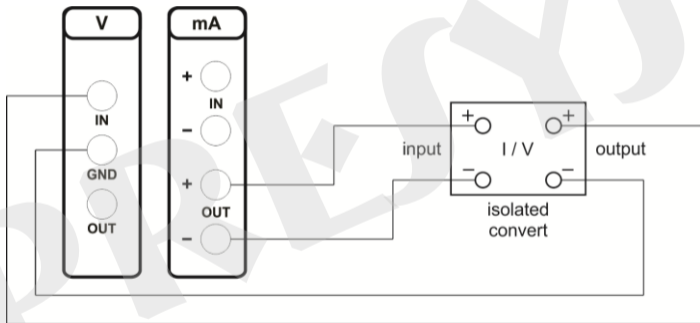

Figure 11 - Isolated I/V Converter

2.8. Special Programming

When **PRG** is selected, the display will show:



This option allows the selection of special programming features for **INPUT** or **OUTPUT**. **INPUT** is provided with **FILTER**, **DECIMAL** and **SPEED** options. **OUTPUT** is provided with **STEP** and **RAMP** options.

2.8.1. FILTER Programming

The value of this parameter (in seconds) configures the time constant of a first order digital filter coupled with the selected input. When the filtering of the measured signal is not required, just set this parameter as 0 (zero).

2.8.2. DECIMAL Programming

The value of this parameter (**0**, **1**, **2**, **3** or **DEFAULT**) indicates the number of decimals that the value measured at the input will be displayed.

Note: **DEFAULT** corresponds to the maximum decimals that LC-505 may display in an input measurement, in accordance with its resolution.

2.8.3. STEP Programming

The **STEP** programming makes LC-505 output vary in pre-defined steps. It is useful in calibrations where certain scale points are verified; for example 0% - 25% - 50% - 75% - 100%.

To enable this programming from the main menu, select **CONF** (ENTER), **PRG** (ENTER) and **STEP** (ENTER). After this sequence, you will have the options **10%**, **20%**, **25%** and **VARIABLE**; these options define the percentage of variation at the output for each step. The **VARIABLE** option allows you to program the setpoint values of each step, up to a maximum of eleven values.

The type of output must be previously configured, otherwise the message: **SELECT OUTPUT FIRST** will be displayed. In this case, press C/CE to go back to the main menu and select the output type.

After the selection of the step variation percentage is completed, the start and the end values of the range within which the output will travel (**Setpoint High and Low**) are asked.

To continue, go back to the main menu and activate **EXEC**, the output now performs the **STEP** programming, always starting from the beginning of the range, and the arrow keys **▲** or **▼** must be pressed when you want to skip to the following steps.

By pressing the arrow key **▶**, each step will be reached automatically after a preset time is elapsed, which is defined through the keys: 1 (10s), 2 (20s), 3 (30s), 4 (40s), 5 (50s), 6 (60s), 7 (70s), 8 (80s) and 9 (90s). These times are only enabled, once the arrow key **▶** has been pressed, what changes the **STEP** mnemonic to 0s. Under this situation, the steps are automatically and permanently scanned. If you wish to quit this mode (**STEP** set by time), just press the arrow key **▶**.

2.8.4. RAMP Programming

By using this programming, LC-505 output varies automatically, thus producing ramps and level marks which may be programmed to actuate once or continuously.

From the main menu, select **CONF** (ENTER), **PRG** (ENTER) and **RAMP** (ENTER). Then you must enter the start and the end values of the range within which the output will travel (**Setpoint High and Low**), and also the value of time (in seconds) required for a complete travel within the range (**Ramp Time**). Another value that may be configured is how long it should dwell at the level mark (**Dwell Time**), that is, the time during which the output remains constant between two ramps.

After the configuration is completed, go back to the main menu and press **EXEC**; then the output goes to the starting value of the configured range. When the arrow key **▲** is pressed, an ascending cycle is started, and by pressing **▼**, a descending cycle begins, only once. Pressing **▲** and **▼**, the cycles are repeated continuously.

2.9. Special Functions

When **FN** is selected, the display will show:



With these options, you may select special functions related to the **INPUT** or the **OUTPUT**.

INPUT has the **SCALE**, **CAL** and **NO** options.

2.9.1. SCALE Function

It establishes a linear relationship between LC-505 input signal and what is shown at the display, according to the graphic below.

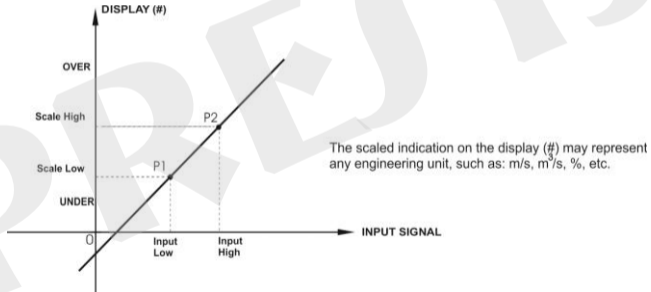

Figure 12 - SCALE Function (LINEAR)

The number of decimals (up to 4) shown on the display may be configured by using **Scale Dec** parameter.

The value for **Input High** must be necessarily higher than Input Low. On the other hand, **Scale High** and **Scale Low** may have any relationship between themselves: higher than, lower than or equal to, and they may have a sign before them. Thus direct or reverse relationships may be established.

For current input, a linear relationship may be established as it has been previously shown or it may be squared (**FLOW**) as illustrated below:

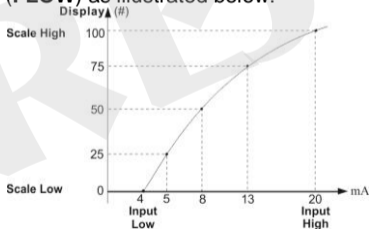

Figure 13 - SCALE Function (FLOW)

2.9.2. CAL Function

LC-505 may be used to calibrate or check isolated converters. In a typical application, it would generate current signal and measure the voltage output signal from the converter. Due to reasons of quickness and easiness to compare errors at the input and output of the converter, the reading of LC-505 voltage input may be displayed in the same unit of the generated signal, that is, current unit. Thus, both readings of LC-505 input and output are scaled in current unit, and the error can be promptly calculated.

To activate this LC-505 function, just fill the four parameters shown in the graphic below. To access these parameters press ENTER after **CAL** is indicated in the display.

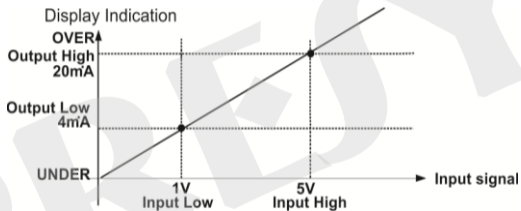

Figure 14 - CAL Function (LINEAR)

Note that when **CAL** function is active, the display will indicate **CAL** instead of **IN**, as illustrated below:

CAL = 12.1000 mA
OUT = 12.0000 mA

To disable **SCALE** or **CAL** functions, just select **NO** option from the menu below and press ENTER.

SCALE CAL ⇒ NO

OUTPUT has the **SCALE**, **CONV** and **NO** options, described as follows.

2.9.3. SCALE Function

The scaling of LC-505 output allows it to simulate the functioning of a transmitter. Transmitter input is made directly by keyboard, and one can get voltage or current output signal.

SCALE output function relates the output signal generated by LC-505 to the value shown on display, according to the example shown below.

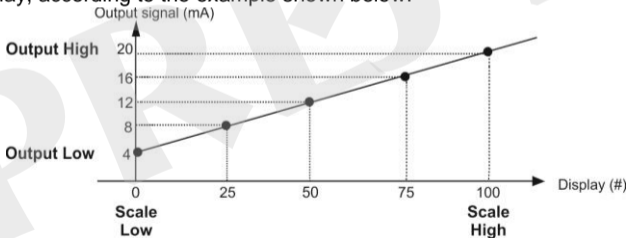

Figure 15 - SCALE Function (LINEAR)

Scale Dec parameter configures the number of decimals presented at the display.

The value of **Output High** must always be higher than **Output Low**. **Scale Low** and **Scale High** parameters can have any relationship between them, provided that they are different. Thus, direct or reverse relationships may be established.

In case of current output, as well as for the input, a linear or squared (**FLOW**) relationship may be established, as it is illustrated below.

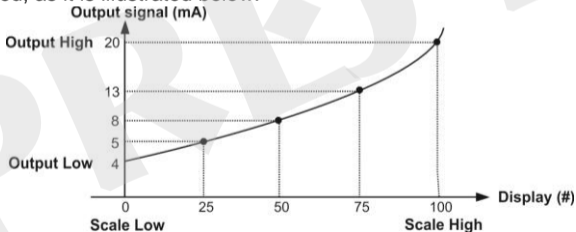

Figure 16 - SCALE Function (FLOW)

2.9.4. CONV Function

By using the **CONV** function, LC-505 may convert any input signal into any output signal, without galvanic isolation. It may therefore behave as a non-isolated converter.

Once LC-505 input and output have been selected, you must fill in the four parameters shown in the graphic below. To access these parameters press ENTER after **CONV** is indicated on the display.

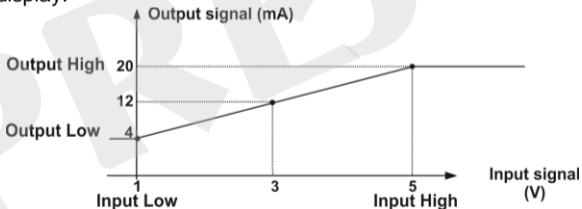

Figure 17 - CONV Function

The value of **Output High** must always be higher than **Output Low**. **Input High** and **Input Low** parameters must never be equal. Thus, any type of direct or reverse retransmission from input to output can be obtained.

SCALE and **CONV** functions can be disabled by selecting the **NO** option and pressing ENTER, as shown below.



2.10. MEM Command

LC-505 multicalibrator offers several programmations and special functions that can be often used. In this case, storing these configurations in the calibrator saves time. One can have up to eight sequences stored in memory.

After making a specific operation in LC-505 through the keyboard, return to the menu that shows **MEM**. Then select **MEM** and press ENTER. The display will show:

| | |
|-----------|--------|
| ⇒ WRITE | RECALL |
| CLEAR ALL | |

Select **WRITE** and press ENTER. The display will show:

| | | | |
|-----|---|---|---|
| ⇒ 1 | 2 | 3 | 4 |
| 5 | 6 | 7 | 8 |

The numbers shown above represent eight locations of memory. Select any of them and press ENTER. LC-505 configuration is then stored in the chosen memory. In order to call it, even though LC-505 has been turned off and on, select **RECALL** (ENTER) and the memory number that stored the previous configuration. Then press ENTER.

Any new configuration can be written over an already used memory location.

When you want to clear all eight memory locations, select **CLEAR ALL** and press ENTER.

2.11. LC-505 Warning Messages

| Warning | Meaning | Procedure |
|-----------------------------|---|--|
| RAM ERROR READ MANUAL | Problem in RAM memory | Turn LC-505 off and on. If the error persists, contact Presys technical assistance |
| EEPROM ERROR READ MANUAL | Problem in EEPROM memory | |
| CHK LOOP | mA output opened | Check the connections |
| LOW BATTERY | Level of battery Voltage is low | Connect the charger to the LC-505 |
| UNDER / OVER | Input signal out of Specifications or scaling range | See item 1.2, on Input Specifications |
| LOW RES | Short-circuit in V output | Check the impedance at the input circuit connected to LC-505 |

3 - Calibration and Maintenance



ATTENTION: To prevent potential damage to the instrument's calibration due to improper adjustments, the access password must be requested from your local distributor.

Adjustment procedure access password: To perform input or output adjustments, the owner of the calibrator must contact the local distributor, providing the equipment's **serial number** to receive the password that allows access to the adjustment.

WARNING: Enter the following options only after understanding them completely. Otherwise, it may be necessary to return the instrument to the factory for recalibration!

Select **CAL** option from the main menu and press ENTER. Then enter the **PASSWORD** to access the calibration menu.

The password works as a protection to calibration ranges. After entering the password, the menu displays the options:



You should then choose whether the calibration is to be performed over an input range (**IN**) or an output range (**OUT**). DATE is an option which allows you to record the date on which the calibration is performed and once it has been filled in, it will be displayed every time the instrument is turned on. The date can only be updated after a calibration (adjust) operation.

Options for **IN** or **OUT** calibration are:

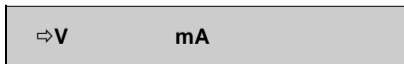

3.1. Input Calibration

Select the corresponding mnemonic and apply the signals presented in the tables below.

When calibrating inputs, the display shows on the 2nd line the value measured by LC 505 and on the 1st line the same value is expressed as a percentage.

Note that the applied signals just need to be close to the values shown in the table.

Once the signal has been applied, store the values of the 1st and 2nd calibration points by pressing keys 1 (1st point) and 2 (2nd point).

| V Input | 1st point | 2nd point |
|----------------|------------------|------------------|
| Single range | 0.00000V | 11.00000V |

| V Output | 1st point | 2nd point |
|--------------|-----------|------------|
| Single range | 0.00000mA | 20.00000mA |

3.2. Output Calibration

Select the corresponding mnemonic, choose the setpoint as explained as follows, measure the signal generated by LC-505 and store this value as detailed in the following tables.

For calibration of outputs, the display shows three kinds of information:

| |
|--|
| SP = 50.000% ⁽¹⁾ 49.999 ⁽²⁾ 5.00000 ⁽³⁾ |
|--|

Field (1) is the value of the setpoint as a percentage (%) of the output range required by the user and it is selected by pressing the key "0".

Field (2) is the value measured by LC-505 expressed in percentage (%) of the output range. Before providing the 1st and 2nd calibration points, one must wait until this value stabilizes.

Field (3) is the value entered by the user after the output has been measured and the values corresponding to the two setpoints have been stored: 1st point (key 1) and 2nd point (key 2).

Press the key "0" to select the setpoint.

| V Output | 1st point | 2nd point |
|-----------------|------------------|------------------|
| Single range | SP = 10.000% | SP = 80.000% |

| mA Output | 1st point | 2nd point |
|------------------|------------------|------------------|
| Single range | SP = 10.000% | SP = 80.000% |

3.3. Replacement of Current Input Fuse

In order to have access to LC-505 fuse, proceed as follows:

- 1) Remove the two screws from the rear panel;
- 2) Remove all five screws from the fixing board;
- 3) Displace the internal part, attached to the front panel out of the box;
- 4) Identify the glass fuse as illustrated in the figure below;
- 5) Replace the damaged fuse by the spare fuse (LC-505 carrying case).

The fuse of LC-505 has special characteristics. Thus, use only the 32 mA fuse provided, code 01.02.0277-21.

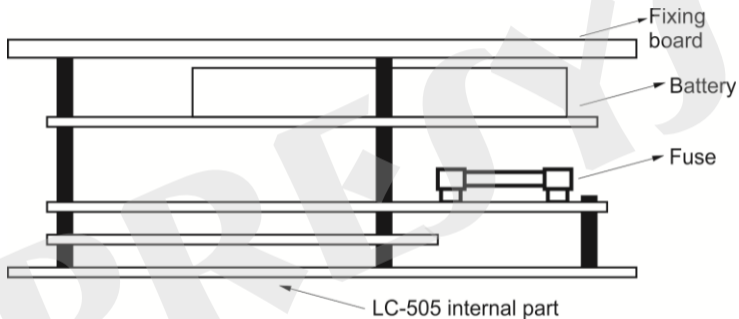

Figure 18 - Replacement of the Input Fuse with Current

Notes:

- Adjustment of LC-505 must be performed under reference conditions of temperature and humidity.
- The minimum warm-up for adjustment is two hours.
- LC-505 power supply must be disconnected from the battery charger during adjustment.
- It is recommended that calibration standards presented to LC-505 during adjustment have accuracy at least 3 times better than the accuracy values provided in this manual.

PRESYS

PRESYS

| Instruments Inc.

www.presys.com.br